



## Interview with Mr. Santosh Birkram Shah

Santosh Birkram Shah is a retired officer of Nepal Government. He was in government service as a forester well trained in forest management. He got his education from universities of India, Germany and USA. During his professional career he served in various responsibilities. He retired from government service as Joint Secretary of Ministry of Forest, Nepal in 1996. He went to West Germany (of that time) for higher studies in Forestry under DAAD fellowship in 1961. He is the second Nepalese student to get fellowship from DAAD, but he is the first one to return Nepal after completing the fellowship. Immediately as he returned from Germany, he joined Forest service of Nepal in 1966. During his professional career he served in different forest management projects and offices of government of Nepal and after retirement from government service worked as consultant in Multi-lateral or Bi-lateral Aid Agency supported projects. He is life member of NEGAAS and members of various professional organizations. On behalf of NEGAAS Journal Dr. Tribikram Bhattarai talked with him on his academic, professional and social experiences. The excerpt of the talk is as follows.

### 1. Mr. Shah, please tell us about your childhood and Kathmandu of that time.

*I was born (12/1938) and brought up in Panipokhari, Maharajgunj, Kathmandu. Except the core city area of Kathmandu the outer areas were sparsely populated up to 1930s and 1940s and there were agricultural fields all around with very fertile paddy fields in the flat lands of the valley, Kathmandu then was a green city. In 1951 autocratic rule in Nepal came to an end and the unplanned urban development of Kathmandu started leading to present day chaotic urban concrete jungle. Garbage was not at all a problem then, every house-hold used to manage garbage at their backyard and the modern day nuisance – the plastic bottles and bags were not in use at all. Kathmandu was a green beautiful city with pure fresh year all year round.*

**2. How was the educational situation of Nepal during your childhood compared to present time?**

*In 1950s there were not many high schools in Kathmandu, Darbar High School was the oldest high school which was established in 1853 in Kathmandu, other reputed high schools were Juddhodaya High School and Padmodaya High School. Boys and girls had separate high schools at that time. There were hardly any high schools in rural areas in the country and in the urban areas very few children of school going age were enrolled in the school, the literacy rate in Nepal in 1951 was less than 9.5%.*

**3. Please say us about your formal education before you started serving Government of Nepal.**

*I was enrolled in class ten in Juddhodaya High School in 1952 and before that I had home schooling. I passed SLC examination in 1953 and then joined Tri – Chandra College, the only college which offered science curriculum at that time in Kathmandu. The college offered intermediate and bachelor courses and was affiliated to Patna University of India. After completing my I.Sc in 1955 and B.Sc in 1957 I was offered scholarship under Colombo Plan to study M.Sc Botany in Calcutta University in India which I completed in 1959. After M.Sc, I worked for around a year in Botanical Section, Ministry of Forest, Government of Nepal. While working there I received DAAD fellowship and I resigned from the government service and left for West Germany in January 1961 to study forestry.*

**4. You got chance to study in Germany under DAAD scholarship. How you got the scholarship? And where you studied in Germany?**

*While working in Botanical Section Office I had applied for DAAD Scholarship to study Forestry in West Germany, the scholarship was advertised in local newspaper by the Ministry of Education, GON. I was awarded that scholarship and I left for Germany in January 1961. In the beginning I had to join four months German language course at Goethe Institut, Radolfzell, Germany, thereafter I was enrolled at the forestry faculty of Albert-Ludwig University, Freiburg and I remained in Freiburg for the whole of my study period which I completed in 1965 with the degree of Diplom Forst- Wirt. I returned back to Nepal in the beginning of 1966 and started working in Forest Resources Survey Office, Ministry of Forest, GON. I worked from January 1966 to 1996 in various capacities under the Ministry of Forest and Soil Conservation, GON, and retired from government service in March 1996.*

**5. Describe us your first trip to German University from Nepal.**

*I left Kathmandu by air to New Delhi and had to stay two days there before flying to Bombay and from Bombay to Rome and from Rome to Munich. I arrived in Munich in the afternoon; DAAD had made arrangement for me to travel by taxi from Munich to Radolfzell, where I had to join Goethe Institute for German language course. It was dinner time when the taxi dropped me at a restaurant in Radolfzell where DAAD scholars from other countries were also present for dinner. I was introduced by the instructor of the Goethe Institute to other students who had arrived in Radolfzell earlier. After dinner I was taken to the room where I had to live during my stay in the institute. Goethe Institute did make arrangements of lodging in private houses and lunch and dinner in a restaurant for all the students who were enrolled for German language course. We were around 20 foreign students attending the language course, from Asia we were four, two from Burma, one from Bangladesh and I from Nepal. The four months long German language course was completed by the end of April, 1961. After completing the language course I travelled to Freiburg and was enrolled at the Forestry Faculty of Albert Ludwig University, Freiburg. I had a friend and classmate from Nepal in Freiburg who was studying medicine there and he helped me a lot to get me going in Germany in early days. Prof Dr. M. Prodan, Department of Forest Mensuration, Faculty of Forest Sciences, was the unofficial guardian for foreign students studying forestry at the university; he used to invite us in Christmas and also in other occasions for dinner and would ask us if we had any problems concerning our studies or living in Germany and would help us overcome difficulties if we had any, he was really a great help to us foreign students.*

**6. Are you the first DAAD scholar from Nepal? How many Nepalese have gone to Germany before you for study?**

*In around 1950s and 1960s not many students from Nepal were studying abroad especially not in continental Europe where the medium of instruction was not English. As far as I know Mr. Bhawani Narsingh Rana was the first recipient of DAAD scholarship in 1960 to study medicine, I followed him in 1961 for studying forestry. While I was in Germany other Nepalese students (around four) came to study in Germany under DAAD scholarship.*

**7. How was your feeling when you started studying in Germany after getting experience of education in Nepal and India?**

*While studying in Nepal or India language was not a problem but in Germany language made it quite difficult for me to follow class room lectures in the beginning; the four months long*

*German language course was not sufficient enough. While attending classes in colleges in Nepal or India there used to be roll call in the class room but in Germany there was no such thing; a student in German academic institution was supposed to be motivated enough to pursue his study diligently on his own. In course of time I was getting familiar with the situation and was able to adapt myself to the academic system in German institutions.*

**8. Say us about your academic achievements in Germany.**

*While in Germany I completed my study of Diplom Forstwirt which consisted of four semesters of Vor-Diplom and 5 semesters of Diplom. Besides class room lectures I had to take up six months of field work within the course duration.*

**9. You completed your study in two different university education systems, of India and Germany. Please say us, how different were the two systems?**

*The education system in India and Nepal followed the British System but in Germany they had their own system. In Nepal and India more responsibility of educating a student was given to a teacher where as in Germany the student himself was made more responsible for his academic achievements wherein the teacher would provide necessary guidance and assistance.*

**10. What were the main difficulties you faced during your stay in Germany.**

*Language was the main constraint in the beginning to be able to mix with German friends so you would shy away from their company and try to be in company of English speaking foreign friends. Secondly, at the beginning there was no student hostel in Freiburg and one had to look for rooms in private houses that one could afford and it was quite a difficult task. Thirdly, in the rented rooms generally you were not allowed to cook and one could not afford to have meals in a restaurant all the time and so one had to resort to cold meals which I did not prefer at all. Once a student hostel and University Mensa was established in Freiburg, the problems for room and food were solved to a greater extent.*

**11. Please say us about the quality of education in India and Germany at that time.**

*There was no disparity in quality of education in India or in Germany but there was difference in the facilities that were available in the institutions. In Germany there were assistants in the departments to facilitate the Head and they would promptly help or advise the students when needed.*

**12. Which aspect of German higher education you liked most and what you think our university education should learn from Germany?**

*In Germany more emphasis is given on the academic development of a student rather than delivering class room lectures. The teachers do motivate the students to investigate further on what was highlighted in the lectures and so it is also in US, I had enrolled for two semesters in 1973 at the University of Washington, Washington State, USA. Such teaching methods should be practiced in Nepal as-well.*

**13. Most of the Nepalese students trained in Western countries at present do not return back after completion of their study. Such brain drain is a serious problem for developing countries like Nepal. But exceptionally you completed your formal education in Germany but still you came back and served here for long time. Did you ever consider staying in the glamorous environment of West? What drove you to come back?**

*It depends upon personal attitude and perception to be infatuated by foreign culture and facilities and to embrace it. I personally never had in my mind to stay in Germany because I thought that I would never be accepted as one of them by the general public though I may have no problems in professional circle. Besides, when I was in Germany we used to have annual gathering of DAAD stipendiaten (scholarship holders) organized by DAAD and in such meetings DAAD would always emphasize how important it was for us to be a part in the development of one's country once you have completed your study in Germany. I was also quite enthusiastic about practicing in my country what I had learned about forest management and development in Germany; Germany is as one of the pioneer countries in the world to practice scientific forest management. Scientific forest management was initiated in Germany 300 years ago.*

*Yes, brain drain is a big problem faced by many developing countries and until and unless the home countries develop a congenial working environment and provide proper facilities, brain drain will continue. Another dimension in brain drain is added at present in developing countries which is the family dimension; the family rather encourages their young members to go abroad for better education and settle there with the hope that they themselves could follow them later.*

**14. You returned Nepal after five years completing your study. Describe us how you felt as you landed in Nepal and started working here after spending long time in different cultural and working environment.**

*I had spent my entire stay in Germany studying German language or attending the Forestry Faculty Courses at the University and had not much of social and cultural mixing with German families. I was allowed to come to Nepal in 1963 during summer holidays for two months and DAAD had arranged the travel and that revived my contacts with family and friends in Nepal. While in Germany I was always eager to come back to Nepal and start my professional career here, getting government job in forestry sector was no problem at that time (1966). My first job was with the Forest Research and Survey Office, a USAID Project; we had American experts working as counterparts and the office was well equipped for field works and desk jobs. During my tenure in government I was most of the time working in projects supported by international agencies so the working environment and facilities were adequate enough.*

**15. Say us about the contribution of your German Degree in your professional career in Nepal.**

*As I have already mentioned, scientific forest management is being practiced since over 300 years in Germany and in 2013 the 300 years of sustainable forest management was celebrated. German scholars have helped to establish scientific forest management in neighboring countries in Europe as well as in India and America. Dietrich Brandis (1824 – 1907) was one of German scholar to have helped in the scientific forest management in India, he was Inspector General of forest in India (1864 – 1883) and was also responsible for establishing the Imperial Forest College in Dehradun, India which was later known as Forest Research Institute (FRI ), Dehradun. During 1950s and 1960s Nepalese exclusively received their forestry education from FRI which was more oriented towards managerial aspects. As sustainable scientific forest management is the main objective for practicing forestry in Germany, this aspect is very much emphasized in the university. The knowledge that I had gained during my forestry study in Germany was very much relevant to my professional career in Nepal and my professional work was appreciated by seniors and colleagues. But unless the government policies and directives are apolitical and conducive to sectoral development, individual efforts do not count much, the forestry sector in Nepal is still lagging behind in many aspects.*

**16. With your own experiences in both countries what would you suggest in Nepalese education.**

*In Nepal more emphasis is given on the full coverage of a subject matter in the class room deliberations (lecture) by the teacher rather than highlighting the main issues and asking the students to research on their own; I think this should be practiced in our educational system. In my time there were no politically affiliated student groups in educational campuses but at present there are many such groups, should not we prohibit such groups and their activities in campuses.*

**17. Once there was a saying in Nepal “The green forests of Nepal is the wealth of Nepal”. But due to the failure of forest management system now a days the forest products are not sufficient for our consumption and huge amount of forest products are imported to fulfill our need. From your experience say us what were the lacking in our forest management system so that the old saying is no more true.**

*It is true that we have not managed our forests properly in past decades; many factors are responsible for this but the main factor was the absence of any long-term plan (vision) for forestry sector. Until 1990 various forestry projects with different objectives were designed and implemented through Donor supports in various parts of the country, these projects had definite implementation period and once that period was completed there was hardly any follow-up activities. In 1989 a Master Plan for Forestry Sector (1989 to 2010) was prepared and implemented, the Master Plan had envisaged twelve programs for the forestry sector of Nepal and outlined in detail the activities of each program. But unfortunately the programs were not supported by the implementing agencies as envisaged by the Master Plan, some programs got priority treatment and others were not addressed at all; the forest utilization aspect was least prioritized in all the management regimes. Working plans /Working Schemes were prepared for almost all Division Forest Offices but they were never implemented, for quite a long time only salvage operation was carried out i.e. only dead and fallen trees were removed from the forest. Even after the formulation of Master Plan the old scenario persisted and sadly the forests (at least the government forests) were not properly managed and the production capability of our forests was not enhanced. Like in every sector in Nepal politics interfered in decision making process that has resulted in the present sorry state of our forests. At present the forests are so much depleted that one cannot produce timber as per the demand of the country.*

**18. Community forest system in Nepal was introduced when you were in Government service which is one of the most successful programs to better manage our forest. What make this system successful in increasing the forest cover?**

*Yes participatory forest management has played a significant role in improving forest quality and protecting the forests in Nepal. To date 1.65 million hectares of national forest have been handed over as community forests to around 22 thousands community forest users group comprising 2.91 million households. This approach was a pioneer approach and has been acclaimed all over. Here again the issue of utilization has come in forefront, the government seems to be quite reluctant to facilitate proper harvesting of forest products from community forests which to some extent would have helped to relieve the shortage of timber supply in the Nepalese market. Community forestry has helped in greening our once denuded hills and helped in increasing the forest cover to some extent. It is also pointed out that the migration of working age population from the hills has contributed to abandoning of the agricultural fields where natural vegetation is established thus helping in increasing forest cover to some extent.*

**19. Climate change is now a burning issue and affecting the life of our citizen massively. One of its causes is the reduction in forest cover and quality. From your experience please say us what should we do to improve our forest to mitigate the problem.**

*Nepal is one of the highly affected countries from climate change though Nepal's share in producing carbon emission in global context is minimal. A well stocked forest would be able to make more carbon sequestration but there are so many other components responsible for environmental degradation and pollution. In recent years, particularly this year (2020/2021) there were many occurrences of forest fire in Nepal and at that time Kathmandu was branded as the most polluted city in the world.*

*In Nepal climate change is characterized by long dry periods during winter and heavy rain (cloud burst) during monsoon. The long dry period is responsible for forest fire in late winter, spring and early summer. Controlling or fighting forest fires is very difficult especially in the mountainous terrain. Minimizing the presence of fire hazardous materials (like under growth) in the forest could help in avoiding forest fires and we can achieve this by proper silvicultural and forest management practices. Once again we would need to overhaul our present forestry sector policy and management practices.*

**20. Let me ask you something on social aspects. Which German food you liked most and which you disliked?**

*I liked most of the German food especially pork cutlets, potato puree, sauerkraut, and so on. In Germany there are many types of sausages available and you could choose from them and I liked sausages. And of- course the German beers, they are world famous, I liked the draft beer most. German wines are good wines and you should not miss the occasional schnapps.*

**21. Now a day German market is internationalized and most of the necessary items one can get there. Have you faced difficulties in getting/cooking proper Nepalese food in Germany, when you were there?**

*While living in rented room in private houses you could not cook your meals and in student hostels other residents in the hostel would complain if your food preparations emitted unfamiliar smell due to use of oriental spices. Whenever I cooked food it would be just boiled rice and chicken with sauce without oriental spices, so I rarely needed any exotic ingredients which were not readily available in the market then.*

**22. You may have found behaviors of German people different from that of Nepalese. Can you say us which behaviors should we Nepalese learn from German. Anything if you like to convey for German as well?**

*Yes, the German people are hard working and dedicated to their profession whatever it may be and this is what is lacking in Nepal. In Nepal even now we are very choosy about work and more concerned about how much you earn from your job.*

*In early 1960s the German people were not exposed very much to international visitors so they would generally shy away from people from Africa and Asia, I guess the situation has changed now. German gemutlichkeit (comfort) is world famous and I would love to relive it in future.*

**23. You are the founder life member of NEGAAS. From your long time working experience with it what do you think in which aspect NEGAAS should contribute more.**

*Late Dr. Basanta Lal Shrestha, late Dr. Dayananda Bajracharya, Dr. Chandra Bahadur Joshi, were mainly responsible in establishing NEGAAS in early 1980s. Now NEGAAS has been in existence for more than three decades and though the association was rather restrictive in including only academic degree holders of German Universities in the initial years, now almost anyone getting academic training or involvement in academic activities in Germany*

*can join the alumni. As the number of members has now increased dedicated younger generation members should be given the responsibility of making the association more vibrant. Talk programs, seminars, social interaction activities etc that would focus on recent developments in academia or socio-environment aspects, could be arranged in regular basis.*

**24. Have you been in Germany after 1966? What remarkable change you observed in your last visit from your first visit there?**

*I did not have the opportunity to go to Germany and stay there for longer period of time after I returned to Nepal after completing my Diplom Forstwirt course except in 1977 August when I was again in Freiburg under DAAD Revisit Program for a period of 3 months from mid August to mid October 1977. Forstliche Versuchs und Forshung Anstallt, Baden-Wurtemberg had organized my study tour. In other time I had couple of days stay in Germany on my way to America in 1973 and on my way to Finland in 1987. I assume that there have been lot of changes as compared to early 1960s and the German gemutlichkeit has been preserved.*

**25. Please mention if anything remains that was more relevant and that you want to mention and suggest?**

*When I was in Germany in early 1960 there were two Germany; West Germany and East Germany and the memories of World War II was still haunting older generation and the partition had affected many families, and many East Germans had escaped from the East and living in West almost as a refugee.*

*In August 1961 DAAD had organized annual meeting of DAAD stiependiaten (scholarship holders) in West Berlin which was inside East Germany, around 100 km from West German border. DAAD had organized the travel and the day we arrived in West Berlin, the Berlin Wall was erected during the night ( August 13, 1961), that is an incident which I still remember, I think the German Wall existed until November 1989.*

*After completing my study in Germany I had decided to travel by ship from Naples in Italy to Bombay in India via Suez Canal. So in January 1966 I embarked on a ship journey of around 10 days on a Italian passenger liner; the journey was quite memorable and enjoyable, the passengers were hugely entertained and all eagerly participated in Captain's dinner, Captain's ball dance, deck games etc.*

**Mr. Shah, it was quite interesting to talk with you about your academic and social experiences of Germany and Nepal. I am sure that this talk will be interesting to German alumni members and all readers of NEGAAS journal. I myself and from NEGAAS journal editorial team I want to thank you for giving this opportunity to us. We all wish for your healthy and comfortable life also with German Gemutlichkeit. Thank you again. Vielen Dank and Namaste.**

# **AN APPROACH FOR MEETING THE FINANCE CHALLENGE TOWARDS THE SUSTAINABLE SOLUTION FOR WATER SECURITY IN GROWING CITIES**

**Ganga Datta Nepal**

Country Team Leader

USAID WASH FIN PROJECT, NEPAL

Email: [ganga.nepal@washfin.org](mailto:ganga.nepal@washfin.org)/[nepal\\_ganga@yahoo.com](mailto:nepal_ganga@yahoo.com)

## **ABSTRACT**

To address the growing water crisis and achieve the Sustainable Development Goals (SDG) 2030, the proper water resources management with realistic planning and investment for water and sanitation is a must. In the developing countries like Nepal, government alone cannot deliver the required water services for the growing urban population, where private sector is less interested and reluctant to invest due to the higher risks and lower returns. The earlier practices of the Public Private Partnership (PPP) approach in water services sector have also provided the mixed results for the sustainable service delivery. Better understanding of the economic value and finance for water resources are required to achieve the set target of managing water supply services of scarce zone. Additionally, formulation of essential and realistic policies, operational strategies or plans for cost recovery and sustainable financing to increase services, particularly for the deprived and poor are equally important. Due to the lack of systematic knowledge, strategies for cost recovery are typically not comprehensive and can fulfil only few aspects of sustainability index. This leads to the degradation and low performance of water supply systems, resulting in failure to deliver the reliable services for the users. For a better living environment in cities, there are new and innovative ways to solve the problem of sustainable financing for water services such as blended finance, leveraging the services, involvement of private sector, promotion of commercial banks for the sustainable financing of infrastructure for water services. Regardless, the real challenge is how to overcome the barriers by increasing the investments and contributions for coping with the problems on water security in consideration with also climate change and natural disasters like floods and droughts, which needs proper mitigation measures and sustainable growth in line with SDG target.

## **KEYWORDS**

Investment, Sustainable, Water Security, Infrastructure, Mitigation

## **INTRODUCTION**

Water supply and demand is increasing day by day as per the increasing population in the cities and the urban centres. Cities are being crowded and unhygienic to live in due to the lack of sufficient water supply facility and also due to lack of proper management system for wastewater and faecal sludge. Now the time has come to start an awareness in municipal management and equal involvement of public towards the treatment of solid and liquid waste.

There should be proper water resources management: realistic planning and investment for water and sanitation can only achieve the Sustainable Development Goals (SDG) 2030. Developing countries like Nepal government alone cannot deliver the required water services for the growing population of cities, still private sector is not interested and reluctant to invest due to the risks and low returns (Shah, 2016). An improved and reliable access to water supply is primordial for social and economic development of the country. It has direct links to public health and wellbeing of the community people. Access to drinking water is essential but not enough to achieve significant improvement of health situation for the urban population. Through these activities, the prevalence of water-borne diseases has been considerably reduced in the targeted population, with a recognized lasting effect. One of the main features is the collection of tariffs. Users' will pay the tariffs to recover the costs of the water supply service to ensure sustainability of the system (Shah, 2016). To set the tariff, there is need to agree upon by the consumer through a fully transparent procedure, independently for each community, which is then presented to the local committee for approval.

The cost and tariff include not only the running costs of the water supply system, like the electricity consumption for pumping, maintenance services, pay for the staffs/ technicians but also the depreciation for repayment through the collected funds saved and deposited at the bank. These remaining funds can then be used either to repay a loan contracted to build the initial water supply system, or to build extensions of the service areas and replacement of the heavy equipment. For the drinking water system, over the years, the money set aside is less important since the water system needs more maintenance. Different experiences from the urban, small towns and semi -urban areas after five years demonstrates that the maintenance expenses increase significantly over the period of time. Similarly, the cost of all investment is reflected in the tariff and is repaid over 5, 10 or 25 years, depending on the type of technology and equipment for their lifespan (Datta et.al, 2015).

## **METHODOLOGY**

The methodology required for the cost recovery business model for the sustainable financing to secure the water for the frequently populated cities and to improve the commercial viability and business planning for water supply operations to achieve full water supply coverage for the city are as follows:

- i. Assessment of performance indicators on existing water supply services for the city

- ii. Estimation of demand facility
- iii. Identification of capacity and willingness to pay
- iv. Financial and accounting analysis of existing water supply services
- v. Business planning based on coverage gap and
- vi. Estimation for capital investment projects towards full coverage

## **RESULTS AND DISCUSSION**

For the city-wide coverage on water supply, an assessment of performance indicators will be done. Then estimation of demand facility will be calculated. There is also investigation to find the capacity and willingness to pay from the consumer. It will be then coupled with the financial and accounting analysis of existing water supply services and forecast for the future. Then there will be gap analysis based on existing situation for the full coverage. The gap analysis will forward the estimation of capital investment projects for the full coverage

### **Consumer Perspective**

For cost recovery business and continuity planning is effective for the requirements of consumer's expectations, it should be a part of the water supply utility's organizational culture. Every organization, including water supply utilities, should have a culture. Although culture is intangible and often taken for granted, it provides a core set of values and assumptions, and guides day-to-day activities of personnel in the workplace. The sustainability aspect of the water supply utilities and authorities at different level, is not an easy system to run. For the progress and delivery success need to be given, capacities need to be developed and trust should be built, which takes time and persuasion.

The cost recovery business model provides information to help consumer to make an initial assessment as capability to effectively utilize new funding and internal resources to accomplish the following goals to achieve;

- Assessment for need system structure; that will provide the demands of our growing service area.
- Enhance capacity of water utility in critical areas related to capital project monitoring and evaluation, asset management, NRW reduction and water quality laboratory establishment.
- Extension of services and attraction of consumer for house connections – on time service provisions for the consumer.
- Management of asset to ensure that operation and maintenance as per the need and to obtain the maximum span of life from investment in water system assets.
- Reduce Non-Revenue Water (NRW), by reducing leakage, replacing and under registering customer meters and eliminating illegal water to provide more water to meet the demand and increase revenues.
- Consumers' grievances handling and satisfaction survey, for the better understanding of the customer concerns and development of plans to meet customer expectations.

## **Business plan Perspective**

The goal of the cost recovery model business plan project is to accomplish the identified, structured and effective utility management planning and prioritization of the tools. The Business Plan includes information about service area, institutional and organizational structure, water supply assets, customer base, and tariffs. It also includes a summary of the most challenging threats and weaknesses that we plan to overcome through the business plan projects as follows:

- Details of each of the plan project goals including activities and cost estimates needed to accomplish each business plan project goal.
- It includes the details on how water utility proposes to finance the capital investment projects that make-up the first business plan project goal (Construct Urgently Needed Infrastructure) and other general improvements.
- The estimated cost, proposed financing plan and timeline to construct these capital projects and other general improvements.
- It includes a list of potential risks and mitigations measures.

**\*NRW:** Non revenue water (NRW) is water that has been produced and is "lost" before it reaches the customer; for ex. pipe leakages.

## **Cost Recovery Model**

The main features of water utility are the collection of tariffs per cubic meter of water provided. This tariff is agreed upon by the population through the fully transparent procedure, independently for each cluster of community, which is then presented to the local agencies general assembly to approve. Tariff includes not only the cost of energy to run the water supply system, operation and maintenance, village maintenance worker (VMW) but also amortization, through the funds saved and kept at the bank. These remaining funds can be used either to repay a contracted loan for the construction of initial stage of water supply system, or to build extensions of the distribution network and/or replacement of the other heavy equipments like treatment systems.

For a cost per capita, the initial investment cost remains affordable, as demonstrated by the amount of systems successfully set and run. This model is advantageous to supply water from the shared tap-stands where all private households will be connected through the watermeters. It will perform better with multi-community cluster where several communities depend on a single source of water, be it underground water or surface water.

## **Affordable and Accepted Tariff**

The tariff is elaborated with the help of community clusters per cubic meters, the initial investment cost remains affordable, as demonstrated by the amount of systems successfully set up and run. It also works for multi-cluster systems where several clusters depend on a single source of water, be it underground water or surface water. Foremost, the initial phase is crucial and requires a strong commitment from the utility. For full coverage and ownership of the

systems, the full engagement of and by the population is required to mobilize the resources for the water supply system, design and construction work and defining the tariff structure as agreed by them through their general assembly, transparent management and control from population, accountability of executive bodies on the technical and financial situation of the system.

### **Water security for the growing cities**

Securing water supply facility directly associated with public healths, economic upliftment, clean and hygeineic environment, also supports the stability on political situation, and disaster risk reduction (DRR). Both the cases of less water and excess water are the factors of vulnerability. When the water is less, people will be insecure and it becomes a public health issue, where excess water means flooding and disaster prone. So, proper management of infrastructure to rely on is the key factor.

Proper water security means management and improvement of resources by minimizing and mitigating associated risks. Also, regular operation and maintenance of water supply and sanitation system will reduce its vulernabvility. Likewise, the drinking water system infrastructure combined with grey and green infrastructure system establishment including proper operation and maintenance of infrastructures will also ensure the water security to meet the demand of the growing cities.

**\*\*Gray water:** water from domestic wastewater generated in households or office buildings from streams without fecal contamination

**\*\*\*Green water:** Green water is the portion stored in soil and potentially available for uptake by plants

Following are the key considerations for implementing water security principles:

- Delivering on demand principle
- Establish cost recovery model
- Effective communications and adaptive management
- Accountability by mobilizing promised resources and fulfilling responsibilities
- Comply with regulations.

Variety of mitigation measures, further improvement and enhancement of system and Non Reveune Water (NRW) principle can be used to improve the water security for the city population. There also should be policy implications for establishing the grey and green infrastructure system, regulatory framework to run it, institutional establishment and along with social and behavious change communications (BCC) measures.

## CONCLUSIONS

Sustainable Development Goal (SDG) 6 reflects towards Clean Water and Sanitation (Shah 2016). It also focuses on water management and increasing water security for water supply sanitation and hygiene (WASH) sector. To cope with the problems on water security; cost recovery business model is one of the most sustainable solutions. This includes how to explore the new 'waterscapes and source protection'. The cost recovery business model provides modality and information to help consumer by providing an initial assessment, to find the capability of effectively utilizing the new funding mechanism as well as to run the internal resources.

## REFERENCES

1. Datta, S., Darling, M., Gonzalez, O. C., Miranda, J. J., De, L., & Zoratto, C. (2015). A Behavioral Approach to Water Conservation: Evidence from a Randomized Evaluation in Costa Rica.
2. DWSSM/ISSAU (2020): Business Plan making directives for water supply and sanitation consumers association.
3. Lambert, A., Brown, T., Takizawa, M., Weimer, D., (1999). A review of performance indicators for real losses from water supply systems. *Journal of Water Supply; research and technology-AQUA*, 48, 227-237.
4. Olmstead, S., Hanemann, W., Stavins, R., (2007). Water demand under alternative price structures, *Journal of Environmental Economics and Management* 54, 181-198.
5. Shah, T. (2016). *Increasing Water Security: The Key to Implementing the Sustainable Development Goals*.
6. SVWSUO (2019): *Business Plan Surkhet Valley Water Supply User's Organization*
7. The World Bank. (2015). *World Development Report 2015: Mind, Society, and Behavior*.  
US EPA. (2013). *Getting in Step: Engaging Stakeholders in Your Watershed*, 2nd ed.



Mr. Ganga Datta Nepal has more than 2 decades work experiences in the field of Water Supply Sanitation Hygiene (WASH), Climate change and Public health sector in multicultural environment both regular development and humanitarian context in national and international arena. The WASH program focused on improving public health: reduce mortality by providing safe and ample water supply and hygienic sanitation. Overall expertise on WASH sector: Project Cycle Management, Project Evaluation, Result Based Monitoring (RBM), Supervision, Capacity Development. Mr. Nepal have high competence in boarder programming with strong skills in project, staff, financial, logistic-management, monitoring, evaluation, business development, donor reporting, coordination, and sector representation. Mr. Nepal holds Post Graduate Degrees from Germany and Nepal, and PG Diploma from the Netherlands, including many other Development Planning Management, WASH, Climate Change and IT based trainings covering technical and managerial aspects. Dynamic personality and having positive attitude, problem solving and have good team dynamics.

# Hydraulic Tunnels in Nepal's Hydropower Plants

**Narendra Bhupal Malla**

## **1. Introduction:**

In Nepal, constructing underground structures such as tunnels in hydropower projects is very challenging, mainly due to the geological & geotechnical conditions. The significant challenge lies 'in structurally unsound rock, shear zones, faults, and other issues related to the region's structural geology complexity. In our Himalayas, the geological challenges occur partly because the mountain range evolved due to the collision of the Indian and Tibetan plates. The rocks were thrown into several folds and fault zones, leading to a disturbed rock mass traversed by several discontinuities. The assessment of the geotechnical features such as shear zones, weak rocks, discontinuities, types of rocks, water bearing layers in the rock, and stability of high cut rock slopes is necessary to design excavation work & rock support system. Recently commissioned & NEA owned Chameliya HEP had suffered a long time from the problem of rock squeezing which made great impacts on the construction schedule & cost of the project. The as-built cost of the project is around NRs.53 Crores per MW. The rock conditions inside the Tunnel may vary from that the surficial features were predicted.



Fig.1. Treatment of Tunnel Squeezing in the Chameliya HEP

---

Mr. Narendra Bhupal Malla is a Civil Engineer with specialization in Structural Engineering with Diplom – Ingenieur from RWTH, Aachen, Germany. He has a wide range of experiences in design and construction of Hydro-Electric Power Projects from 6.2 MW Puwa Khola HEP to 456 MW Upper Tama Koshi HEP. As Design Chief, he had worked in 144 MW Kali Gandaki 'A' HEP and 72 MW Mid-Marshyangdi HEP entire their construction period. He also worked for Tractebel Engineering GDF Svez as Chief Design Engineer in preparing Detail Design Report of 1200 MW Budhi Gandaki HEP. As Senior Design-Hydropower, he had worked in preparing the DPR of Phukot HEP and Betan Karnali HEP for NEA Engineering Company. Recently he completed his job as Design Expert in preparing DPR of WB funded Gabral-Kalam HEP & Kari Muskur HEP for Pakhtunkhwa Energy Development Organization, Pakistan.

Practically, it is impossible to make drill holes to the depth of the tunnel axis & along its alignment. The average cost of drilling in rock lies about 25 -30 Thousand Rupees per meter.

## 2. Types of Tunnels:

The hydraulic tunnels of hydropower projects carry discharges of varying magnitude at different pressures depending on the season. The prime concern is that the tunnels should not leak at any condition because the discharge generates electrical power. The tunnels should remain operational in all conditions, including big Earthquakes too.

**1. Head Race Tunnels:** The headrace tunnels are an important part of the hydro plant. They bring the discharge from the intake to the vertical shaft. Mostly the headrace tunnels are very long. The rock cover of the Tunnel needs to be checked at different locations. In Kali Gandaki 'A' Hydro Plant, the headrace tunnel is 6.00 km long and has a finished diameter of 7.4 meters.

**2. Free flow Tunnels:** The headrace tunnels maybe like an open canal with a free flow type. The discharging capacity depends on its size, nature of wall finishing and gradient of the invert. In Puwa Khola Hydro-Electric power plant with installed cap.6.2 MW, the free flow tunnel had been adopted.



Fig.2 Tunnel Portal under construction.

**3. Mild Pressure Tunnels:** The headrace tunnels may be designed for mild pressure. The internal water pressures may exceed the external water pressures in a certain season. Similarly, the external water pressures may be greater than the internal water pressures in the Monsoon season. They are known as porous tunnels too. In Kali Gandaki 'A' HEP, the Tunnel was designed as a porous type.

**4. High-Pressure Tunnels:** The tunnels with a high longitudinal gradient will have very high internal water pressure & external water pressure in different operating conditions. Since the internal water pressures have to be transferred to the surrounding rock, -pressure tunnels need to be aligned with good rocks. Before finalizing the design for high-pressure tunnel detail, geological and geotechnical investigations are necessary to identify the shear zones, weak zones in the alignment. The rock cover above the Tunnel has to be checked to make it safe against hydro-jacking.

In Upper Tama Koshi Hydro Electric Project, part of the headrace tunnel was designed as a high-pressure tunnel. As given in the tender design, the headrace tunnel had a length of 4946 meters with a gradient of 8 Percent. The design had to be modified as the shear zone was detected at the end of Tunnel. The modification in the Tunnel was necessary because the surrounding rock was not strong enough to take the internal water. The design change in the middle of construction had very big implications on cost and project schedule.

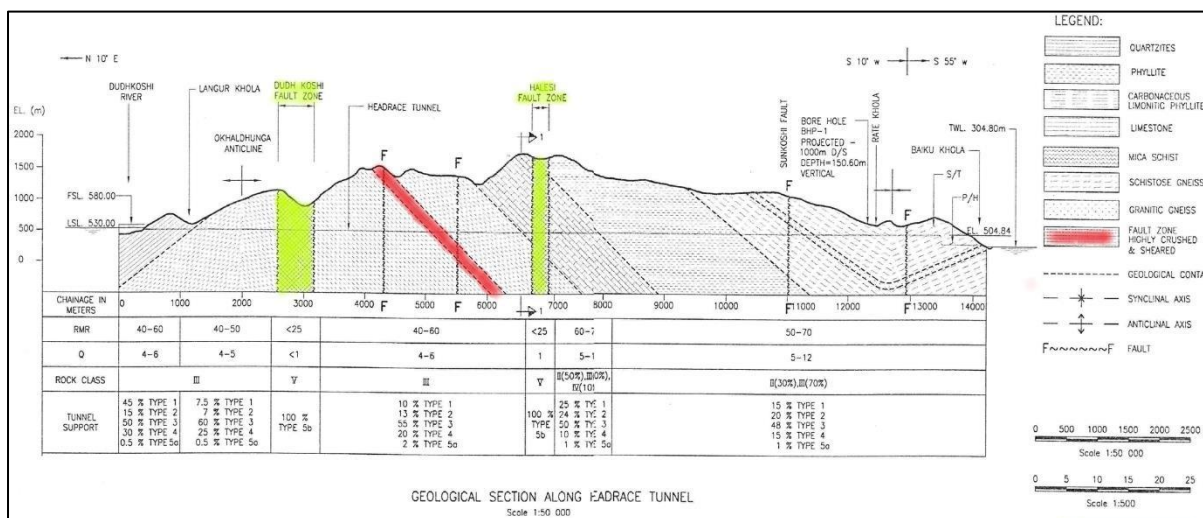

Fig.3 Profile of the Tunnel Alignment showing the Types & Classes of rocks with the Chainage.

**5. Vertical Shafts:** It has a similar function as the headrace tunnel to bring the discharge to the powerhouse. The method of construction is different from that of tunneling. In Kali Gandaki ‘A’ Hydro Plant, the vertical shaft with 7.4 meters finished diameter is steel lined. The construction of steel-lined shaft is a very difficult task due to different reasons.

**6. Tailrace Tunnels:** The tailrace tunnels bring the discharge from the powerhouse to the river. Depending on the Turbine, they may be free flow type or pressure flow type. Normally the tailrace tunnels will be free flow type for Pelton turbines and pressure flow with Francis turbines due to submergence.

**7. Unlined Tunnels:** The unlined tunnels are best suitable if the surrounding rock mass is good, hard, impermeable, and very resistive against erosion & does not contain any minerals which are soluble in water or does not react with water and the joints are very tight that the leakage is least possible. It is a very economical type of Tunnel as it saves the cost for the concrete lining. But there are possibilities of falling of rock pieces with eroding of shotcrete. In general, rock traps are arranged at the end of Tunnel.

**8. Lined Concrete Tunnels:** The concrete-lined tunnels are the solutions when the rock mass shows the high permeability value with leaking possibilities, highly fractured, wider joints & shows the contents of minerals soluble in water. The concrete lining has to prevent the leakage possibilities and has to take the internal water pressures and the external water pressures depending on the seasons. The head loss due to the friction in concrete-lined tunnels is relatively very small. Due to the possibility of fine hair cracks on the concrete due to temperature difference, shrinkage effects and effects of construction joints, there is always some possibility of seepage. To avoid the concentration or achieve uniform distribution of fine hair cracks in the concrete, it is on the practice to provide a minimum amount of reinforcement.

**9. Reinforced Concrete Lined Tunnels:** If the Concrete lining of the Tunnel has to take the water pressures from the inside and from the outside, which depend on the conditions of operation, the lining needs to be analyzed & designed as the reinforced concrete. When the Tunnel has to be emptied for any reason, such as maintenance works, the lining has to take the outside water pressures. During the normal operation time, the net inside pressures on the concrete tunnel change with the groundwater levels, which vary with the seasons.



Fig.4 The reinforcement work in the RCC Lining of Tunnel (Typical)

The reinforced concrete lining is an important part of the hydraulic Tunnel in all hydropower plants. It must be safe against all types of pressures due to water, grouting, rock loads, possible rock deformations, earthquake shaking and temperature variations.

**10. Steel Lined Tunnels:** Tunnels with very big water pressures are preferred to be provided with steel lining as the steel has higher values of allowable stresses. The internal water pressures have to be transferred to the backfill concrete & surrounding rock. The steel liner has to take the external water pressures in all conditions. As the steel lining is confined due to its position, buckling analysis is necessary in many cases. As the steel pipe has a very high value of impermeability, any seepage through the pipe has to be neglected. The construction method is not very simple as the pieces of steel liners have to be transported, placed in exact position, welded together & checked with an X-Ray test for joints. Steel-lined tunnels are cost expensive and take a relative longer time for complete.

### **3. Geological & Geotechnical Investigation:**

The geological and geotechnical conditions are the main factors that will decide whether the option of hydraulic Tunnel is feasible or not. The first thing has to do is the intensive study of the geology and geotechnical conditions of the area with site explorations. The first step is to prepare the Report on Geology with geological mapping of the project area showing all the Type & Class of rocks with shear zones & faults & any other which are important for the construction of tunnel.



Fig.5 Welding of steel liner in the penstock tunnel(Typical)

### **3.1 Geological Mapping:**

The geologist team make the site visit of the project area & prepare the Report on Geology with geological mapping. The idea of making a hydraulic Tunnel with its accessories will be discussed & prepared on these findings of the site. As per requirements, additional study and mapping of the project area will be done. The mapping has to show all important geological features like rock exposures, colluvium, alluvium, landslides, unstable areas and geotechnical features like dip, strike, planes, discontinuities.

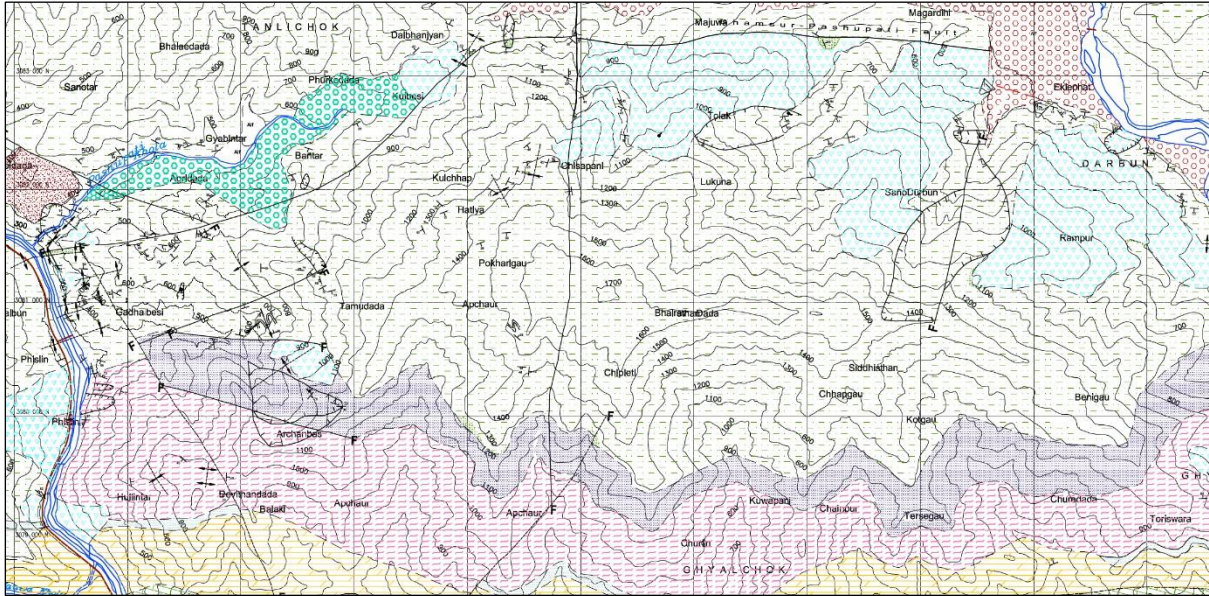

Fig.6 Plan view of geological mapping for the Headrace Tunnel Alignment Area(Typical)

### 3.2 Geophysical Explorations:

Geophysical investigations like Seismic Refraction Test (SRT) or Electro Resistance Tomography (ERT) will be done to collect the preliminary information of the geological features of the ground conditions like rock, weathered rock, overburden concerning the elevations.

### 3.3 Core drilling:

Core drilling is a more accurate method to obtain information about the ground conditions. The drilling has to be done in the areas where the structures will have their foundations. It may be difficult to make drill holes along the tunnel alignment and to the elevation of the tunnel axis as walking along the alignment might be very difficult and most probably, the Tunnel lies very deep below the ground surface. Drill holes will be located near the Tunnel as close as possible. The depth of drilling will depend on the locations depending on the overburden. The parameters like RMR-Values and Q-Values calculated using the cores obtained from the drilling are used to make different rock classes.

### 3.4 Lab Tests:

The parameters like Poisson Value, UCS-value, and E-Module Value required for design purposes are obtained by carrying the lab-tests on the core samples obtained from the drilling.

### 3.5 Test tunnels

In many projects, test tunnels were built to explore the rock conditions of the tunnel alignment already in detail design time much ahead of the project construction. The test tunnel was used for construction purposes. This method is very helpful to prepare the more exact design of the rock support system and gives more information about the rock conditions of the Tunnel. If necessary, several tests like convergence tests or hydro-fracturing tests can be done.



Fig.7 Sectional View of a test tunnel showing the excavated surfaces.

#### **4. Design:**

##### **4.1 Hydraulic Design:**

The hydraulic tunnels of the hydro plant have the main function of carrying the discharge. The discharging capacity depends on the size of the tunnel & flow velocity. With smaller sections the flow will have higher velocity and higher head loss. With a bigger section, the head loss will be smaller as the flow velocity will be smaller. An optimum size of the Tunnel is determined to find the economical solution. The eroding action of the flow will be higher with a higher velocity of the flow.

##### **4.2 Structural Design:**

The concrete lining of the Tunnel is an important part as it has to take the water pressures developed at different times and should prevent water leakage. The concrete & reinforcement design of the concrete lining has to be done according to the analyses. For analysis purposes, different computer programs are in use, but the design parameters have to be determined as per site conditions of the project.

### 4.3 Geotechnical Design:

Typical design of Rock Support System(Typical)

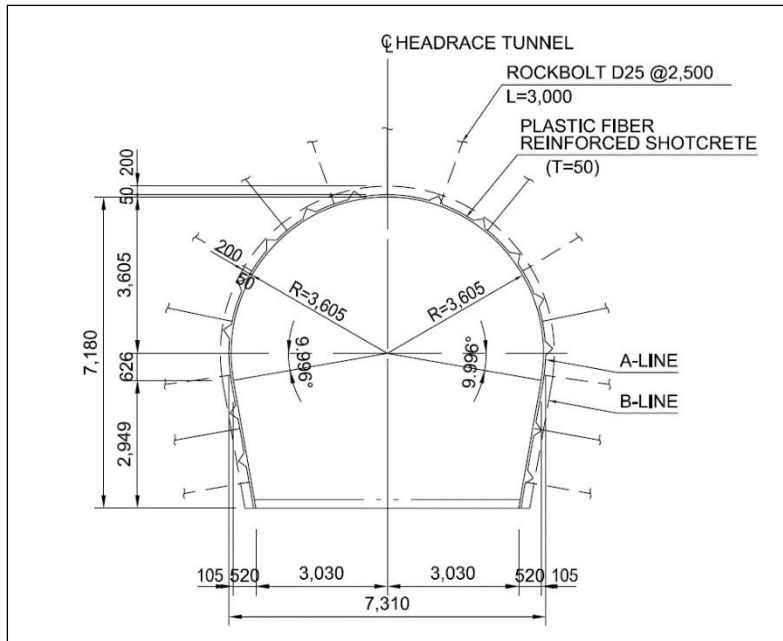

The geotechnical design based on the rock class intends to make the opening stable and safe in all working conditions. According to Q-Values determined from the core samples of drilling the rock, class is made. It is the important part of the tunnel construction that makes the tunnel safe and determines the cost as well. In general, the permanent rock support system contains following

Fig.8. Tunnel section showing the Design of Permanent Rock Support system for the Tunnel

Items:

1. Wiremesh reinforced shotcrete of required thickness.
2. Installation of Rock bolts of required diameter and length at required spacing.
3. Installation of Steel Beams in required sections only
4. Reinforced Concrete Lining of required thickness.

Steel beams & Reinforced Concrete lining have to be provided only in poor & very poor rock class.

### 5. Construction:

The hydraulic Tunnel is the major civil engineering structure in every hydropower project construction from the cost and schedule points of view. Any delay in the tunneling work will have several implications in the cost and the completion period of the project. Early-stage in the planning of the project, it is necessary to discuss and think about the methods of how the tunnels will be built and the duration that may need to complete. In many projects, temporary tunnels called construction adits are made to connect the main tunnel Tunnel from different locations so that the tunneling work can be proceeded from several fronts simultaneously. The average tunneling progress is about 3.00 meters per day per shift, as experienced in many similar projects. The adits are closed with a concrete plug so that there is no leakage. The tunnel construction is always associated with many uncertainties. The rock conditions inside the Tunnel may be quite different from what is seen on the surface.

#### 5.1 Construction Methods:

In Nepal, most of the tunnels of hydro plants are built by applying the Standard Conventional Drill and Blast Method.

**5.1.1 Conventional Standard Drill & Blast Method:** This economical method does not demand a big initial investment in the beginning. The main advantage is that the contractor can mobilize and continue the tunneling work on multiple fronts if the construction adits are provided at different locations. The contractor can continue the tunneling work on other fronts if problems are encountered in one front. However, the progress rate depends on the skill of the team. Drilling, blasting, muck transportation, dumping and rock support installation are the main activities of this method.

**5.1.2 Tunnel Boring Machine (TBM):** The main advantage of this method is that it gives a very high progress rate and the activities as shotcrete, rock bolts installation are mechanized. The design and assemblage of Tunnel Boring Machine will be done according to the rock types, rock class, opening sizes and site conditions, that in general will require a relatively long time and big investment. It may be problematic and in many cases, certain modifications in programming may be required to make the performances suitable to new ground conditions. TBM is best suitable when the ground conditions do not vary much. The progress rate was observed about 30 meters per day on average.



Fig 9.1 Showing the TBM in Bheri Babai Project



Fig 9.2. Showing the Molecular Head of TBM used in Bheri Babai Project.

## 5.2 Construction Schedule:

The schedule is very necessary and important to keep the tunneling work on track and achieve the key dates of important milestones so that project can be completed as per schedule.

## 5.4 Contract Documents & Technical Specifications:

They are legally binding to the contractor. The contract documents are based on FIDIC according to the type of Contract. Unit price-based contracts and EPC contracts are in practice

nowadays in Nepal. , The mode of payments, is not the same in both contracts. NEA-owned UT-3A was executed as an EPC Contract with a soft loan from China. NEA sister company Rasuwagadhi Hydropower Company-owned Rasuwagadhi HEP is being executed with EPC Modell.

The technical specifications are binding concerning everything related to the construction materials, their qualities & execution methods in the construction.

Since the tunneling works are associated with many uncertainties, a new type of Contract with sharing of Risks is in practice in European countries' projects.

### 5.5 Safety issues in tunneling:

Tunnel works are associated with many risks if the safety rules and monitoring are not well maintained. There are certain standards & methods which have been developed especially for underground works for safety reasons. Special training and directions will be given to the team work according to the project's site conditions. There should be adequate lighting and ventilation in the Tunnel and the workers should be in a safety outfit while working. In Kali Gandaki 'A' HEP construction, a separate unit was responsible for monitoring the safety issues throughout the construction period. Similarly, in the Middle Marshyangdi HEP, a separate unit was responsible for safety business.



Fig.10 Showing the Personal Safety Outfit for the Team of Tunnelling Work

### 5.6 Environmental Impacts:

a) The blast creates ground vibrations, the intensity of which depends on an explosive charge and distance. The peak particle velocity exceeding the permissible values will create problems

for houses and their residents. Due to all these reasons blasting very near to fresh concrete is not very desirable. It depends on the distance, nature of ground conditions and amount of explosive used per blast.

b) It is necessary to study the area where the excavated materials will be dumped to prevent the development of all types of adverse impacts like slope wash.

c) With the construction of Tunnel, the part of the river between the Dam site and the power house site will have only minimum flow. It may affect the surrounding area's groundwater conditions, which must be studied well before the project execution.

## 6. Cost:

The breakdown of tunnel construction cost is as follows:

1. Cost of Rock excavation.
2. Cost of Shotcreting.
3. Cost of Rock support system.
4. Cost of Concrete lining:
  - Concrete
  - Formwork
  - Reinforcement

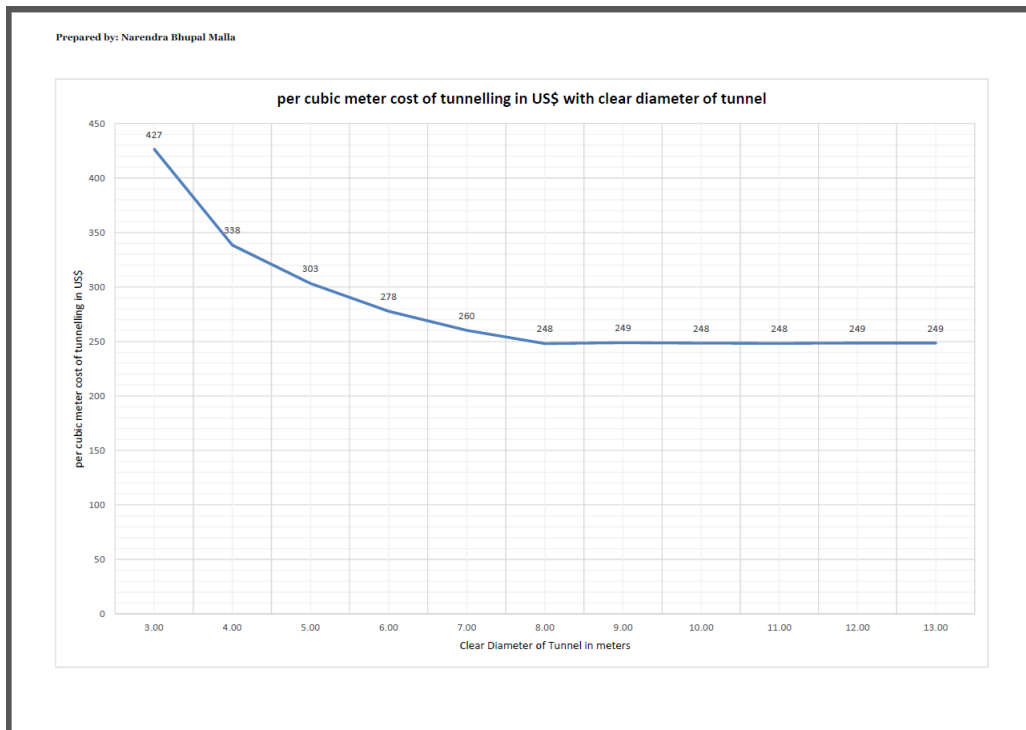

Fig.11 Estimation of Per m<sup>3</sup> cost of concrete lined hydraulic tunnels in Fair to Good Rock class.

## 7. Commissioning:

After completion of the construction, Water filling in the Tunnel will be started according to the procedures given in the manuals. The general procedure is that it has to be done in steps with partial filling and then after some time, the Tunnel will be emptied. After checking the conditions in the Tunnel in detail the Tunnel will be refilled with more water. The same procedure will be repeated. It takes several weeks. It is not permitted to fill the Tunnel in one step as per design.

### **8. Instrumentation:**

The main purpose of instrumentation is to monitor the behavior of the structure with time. The observations are made at regular intervals of time. Readings have to be done regularly at equal intervals of time. The collected data will be analyzed to check if it is working properly. The instruments fixed at different positions in the headrace tunnel will register the responses for the following purposes:

1. Crown settlement
2. Convergence of the tunnel section
3. Rock bolt axial force
4. Underground displacement
5. Stresses on the Shotcrete
6. Pore water pressures
7. Full crown settlement

### **9. Conclusion:**

The Hydraulic Tunnel is the major cost item in any hydropower plant & is fully dependent on the type & class of rocks. The construction of HRT in Nepal is very challenging as there are always many uncertainties associated with the quality of rock. It is always better & the project will be benefitted if the geological investigation will be done more in detail. The design & construction of tunnel will be benefitted with the involvement of Engineers who had done the similar jobs in the past.

Tunnelling works are always associated with some health risks. With the motto “ Safety First” the safety measures like providing the necessary training & providing the personal protection equipment (ppe) for the tunneling team are very necessary to avoid any type of undesirable accidents.

To complete the construction of the project in time so that the electricity generation will start as per schedule it is very necessary to complete the tunneling work as per schedule, that is also related with the selection of Contractor.

### **About the Author**



Mr. Narendra Bhupal Malla is currently working as a freelance consulting person. Mr. Malla has more than 35 years of work experience in planning, designing and construction of hydropower projects ranging from 400kW to 1200 MW. Mr. Malla has a very sound knowledge on hydropower development project and worked on various project funded by national and international organization such as World Bank, MWH-Chicago & NEA etc. Mr. Malla core expertise areas are Planning, designing and construction of hydrp-power projects.

## **Ncell and ongoing ADR Proceedings: Assumption and Expectation**

Madhab Raj Ghimire, \* Narayan Ghimire, \*\* Ronika Thapa\*\*\*

### *Abstract:*

There is a pressing need of reviewing the existing international tax regime to address the complexity of growing cross-border business transactions. The Ncell tax case debated publicly for years is one of the instances of the inadequate tax regime which requires to be addressed in both national as well as international level. This paper sheds light on what the Ncell tax issue was all about, its ongoing proceedings, the roots of the issue and possible solutions.

### **Introduction**

Globalization of the world has allowed businesses to conduct cross-border operations in search of greater opportunities and profits. An increase in multinational companies increases job opportunities and revenue in host countries but it also brings underlying issues like tax disputes among other things. Transaction taking place in multiple countries may sometimes create confusion as to whose jurisdiction the transaction comes under. Decision making in these issues is sensitive because such decisions affect the attractiveness of foreign investment in a country.

One such issue faced by Nepal was the Ncell tax issue. Ncell, a leading telecom giant of Nepal was dragged in a huge controversy of tax evasion since 2016 when its parent company traded Ncell's share to another company. The debate led to serious protests, campaigns like #BoycotNcell, and even attacks in its properties. Despite Ncell's claim of not being liable for the tax, the court made it liable. Eventually, it paid all the dues but it has sought arbitration in the issue which is pending in an international tribunal.

### **Background: The Ncell Tax Issue**

Ncell was owned by three different partners. Telia Sonera owned 60.4% of Ncell through its subsidiary Reynolds Holdings Limited, registered in St. Kitts and Nevis.<sup>1</sup> Similarly, 19.4% of Ncell was owned by SEA Telecom Investments B.V.<sup>2</sup> Remaining 20% of Ncell's stake was held by a Nepali citizen, Niraj Govinda Shrestha to fulfill the requirement of 20% local ownership as required by Nepal Telecommunications Policy, 2004.<sup>3</sup>

---

<sup>1</sup> Rupak D. Sharma, *Malaysian giant acquires 80 percent stake in Ncell for 1.36 billion US Dollars*, THE HIMALAYAN TIMES, (Dec. 22, 2015), <https://thehimalayantimes.com/business/malaysian-giant-acquires-80-per-cent-stake-ncell-1-36-billion-us-dollars/>.

<sup>2</sup> *Id.*

<sup>3</sup> Sanjeev Giri, *IRD examines tax issues in sale of shares*, THE KATHMANDU POST, (Jan. 27, 2016), <https://kathmandupost.com/money/2016/01/27/ird-examines-tax-issues-in-sale-of-ncell-shares>.

In April 2016, Axiata Berhad, Malaysia, through its wholly-owned subsidiary- Axiata Investment UK, acquired 80% of Reynolds Holdings from Telia Sonera UTA Holdings (a subsidiary of Telia Sonera) and SEA Telecom Investments B.V. at \$1.365 billion. This *ipso facto* made Axiata the owner of an 80% stake in Ncell. As a part of the deal, the remaining 20% stake of Ncell held by Niraj Govinda Shrestha was purchased by a local partner - Sunivera Capital Ventures for \$48 million.<sup>4</sup> The capital gain tax of Rs. 2.83 billion resulting from the sale of the 20% stake was paid by the seller, Niraj Govinda Shrestha.<sup>5</sup> However, Telia Sonera left the Nepali market smoothly without any tax liability in the name of an offshore indirect transaction.

Since this kind of transaction was new in Nepal and there was a lack of clear law regarding whether Ncell should be taxed or not, the authorities were confused about whether to impose capital gains tax on Telia Sonera or Ncell. Telia Sonera argued that it was not liable to pay any tax in Nepal because the deal was concluded outside Nepal and Axiata also denied its liability asserting it had no such liability as a buyer. However, the huge transaction created a public debate even before the formal deal was signed. Telia Sonera asked the Inland Revenue Department on whether the deal was taxable in Nepal when Reynolds (which ultimately means Ncell) was owned by Telia Sonera Norway Nepal Holdings and there was a Double Tax Avoidance Agreement (DTAA) between Norway and Nepal that allowed Telia Sonera to pay tax only in Norway.<sup>6</sup>

In April 2017, the deal was told to be taxable in Nepal by Office of the Auditor-General as per Section 57 of the Income Tax Act, 2002 (hereafter referred to as “the Act”) for the first time, following its 54th annual report and it was stated that the government needed to raise Rs.32 billion as capital gains tax from the buyout deal worth Rs.144 billion for 80 percent stake.<sup>7</sup> Under the Act, the rate of capital gains tax for foreign investors is 25% out of which 15% has to be paid by the company that was sold (Ncell), and the remaining 10% has to be paid by the seller (Telia Sonera).<sup>8</sup> After public and government pressure, Ncell paid Rs. 9.96 billion in May 2016 as a 15% withholding tax for capital gains out of 25% by assessing the tax amount on its own.<sup>9</sup> Self-assessment of tax based on its transaction is allowed, but the authority may conduct a tax assessment on its own if it does not believe in the assessment or taxpayer does not pay the tax.<sup>10</sup> Yet, Telia Sonera refused to pay the remaining tax. After that, the Large Taxpayers’ Office (LTO) in June 2017 determined the total tax liability of Rs. 60.71 billion.<sup>11</sup> Till then, Ncell had already

---

<sup>4</sup> *Id.*

<sup>5</sup> *Axiata take charge of Ncell from TeliaSonera*, THE KATHMANDU POST, (Apr. 13, 2016), <https://kathmandupost.com/money/2016/04/13/axiata-take-charge-of-ncell-from-teliasonera>.

<sup>6</sup> Sanjeev Giri, *IRD examines tax issues in sale of shares*, THE KATHMANDU POST, Supra note 3.

<sup>7</sup> Bibek Subedi, *Auditor General’s Office questions Ncell Deal*, THE KATHMANDU POST, (Apr. 13, 2017), <https://kathmandupost.com/national/2017/04/13/auditor-generals-office-questions-ncell-deal>.

<sup>8</sup> *SC orders recovery of capital gain tax from Ncell*, SETOPATI, (Feb. 6, 2019), <https://setopati.net/social/139075>

<sup>9</sup> Bibek Subedi, *LTO plans to conduct tax assessment of Ncell deal*, THE KATHMANDU POST, (Jul. 17, 2016), <https://kathmandupost.com/money/2016/07/17/lto-plans-to-conduct-tax-assessment-of-ncell-deal>

<sup>10</sup> *Id.*

<sup>11</sup> *House Panel to Govt: Recover Taxes from Ncell Immediately*, THE KATHMANDU POST, (Jul. 14, 2017), <https://kathmandupost.com/money/2017/07/14/house-panel-to-govt-recover-taxes-from-ncell-immediately>.

deposited total tax of Rs. 23.6 billion. The government barred Ncell, Axiata, Reynolds Holdings, and companies associated with them to repatriate dividends until the tax issue was settled, as a measure of pressurizing them.<sup>12</sup> But later in December 2017 in a writ order, Supreme Court allowed repatriation to protect the company and shareholders.<sup>13</sup>

Following the order, in January 2018, a writ was filed in the Supreme Court to make Ncell liable for the capital gain tax. In the verdict of the extended full bench of Supreme Court in February 2019, it held *inter alia*, that Ncell and its parent company Axiata were liable to pay capital gain tax because Telia Sonera had already exited and Ncell's business was based on Nepal.<sup>14</sup>

### **The Supreme Court Verdict**

The Supreme Court accepted writ jurisdiction in this case holding that Ncell was a prominent taxpayer and the tax in question would affect the Nepali economy substantially. The transaction was held to be an Off-shore Indirect Transfer (OIT) of assets to avoid tax. The court recognized a lack of uniformity in the international practice of treating the sale and purchase of shares through conduit companies. Nevertheless, it held that the transaction can be brought within the purview of the Act as an offshore transaction of the property of the residential company of Nepal.

In this case, Ncell was a residential person of Nepal and its property was disposed to the Axiata through Reynolds Holdings; the majority shareholder of Ncell with effective management on it. The source of the property disposed belonged to the resident person of Nepal (Ncell) under Section 67 of the Act and the tax could be levied on the gain from such disposal as per Section 57(1) of the Act. The court established that Ncell had to bear the liability of the tax. Similarly, tax avoidance under Norway Nepal DTAA could not be invoked here by Telia Sonera because of restriction of treaty shopping under Section 73(5) (b) of the Act. Based on the decision, the Large LTO in April 2019 decided the amount and a mandamus of 3 months was given to Ncell to pay the due amount of Rs.39.06 billion in a week.

Ncell moved to the Supreme Court challenging that tax amount assessed by LTO violated due process and the Supreme Court ordered a reduction in Ncell's liability to a total of Rs.45 billion, which meant Ncell had to pay only Rs.22 billion more.<sup>15</sup> Despite the reduction of tax, Ncell was not satisfied and consequently, it sought arbitration.

---

<sup>12</sup> *Large Taxpayer Office serves Notice to Former Ncell Owner*, THE KATHMANDU POST, (Jan. 4, 2018), <https://kathmandupost.com/money/2018/01/04/lto-serves-notice-to-former-ncell-owner>.

<sup>13</sup> Prithvi Man Shrestha, *What Ncell Tax Dispute is All About*, THE KATHMANDU POST, (Dec. 26, 2019), <https://kathmandupost.com/money/2019/12/26/what-ncell-tax-dispute-is-all-bout#:~:text=On%20February%206%20this%20year,seller%20does%20not%20meet%20its>.

<sup>14</sup> *Id.*

<sup>15</sup> Dr Matti Kohonen, et al., *Trapped in Illicit Finance: How abusive tax and trade practices harm human rights*, 20, (Sep.2019), <https://www.christianaid.org.uk/sites/default/files/2019-09/trapped-in-illicit-finance-report-sep2019.pdf>.

## Arbitration in ICSID

In December 2019, Axiata UK and Ncell filed a request for arbitration in International Centre for the Settlement of Investment Disputes (ICSID) under UK-Nepal BIT that allowed invoking ICSID jurisdiction for the settlement of disputes.<sup>16</sup> They demanded remedies including restitution of sums already paid and a permanent injunction against the government to collect capital gains tax from Ncell, along with the damages for all losses suffered due to Nepal's conduct.<sup>17</sup> Following the request for arbitration, ICSID issued a provisional order preventing the Government of Nepal to collect the tax in dispute.<sup>18</sup> There was no clarity on whether the interim order was binding over the Supreme Court order.<sup>19</sup> Some opined that Nepal could not deny the interim order issued by the ICSID tribunal because it was a party to ICSID convention.<sup>20</sup> Despite the ongoing arbitration proceedings, Ncell paid the due tax and interest in April 2020 claiming it to be without prejudice to Ncell and Axiata UK's position in the arbitration.<sup>21</sup> As of August 2020, the case remains pending in ICSID.<sup>22</sup>

Axiata and Ncell appointed Dutch national Albert Jan van den Berg as the arbitrator but Nepal remained silent.<sup>23</sup> So, Korean national Joongi Kim is appointed as the president, and US national Paul Friedland was appointed as another arbitrator of the tribunal by the Administrative Council of ICSID as per Article 38 of the ICSID convention.<sup>24</sup> Though Nepal did not appoint arbitrators from its side, it furnished a reply to the tribunal stating that the issue comes under Nepali jurisdiction and is *sub judice*.<sup>25</sup> The latest development on the case is the issue of procedural order by tribunal concerning the privacy of documents in July 2020.<sup>26</sup>

## Assumptions and Expectations

---

<sup>16</sup> Dr Matti Kohonen et al., *Trapped in Illicit Finance: How abusive tax and trade practices harm human rights*, *Supra* note 15 at 20.

<sup>17</sup> Media Statement, *Axiata Confirms Issue of Provisional Measures Order in Favour of Axiata UK and Ncell by Tribunal in BIT Arbitration*, (Dec.19,2019), [https://disclosure.bursamalaysia.com/FileAccess/apbursaweb/download?id=99569&name=EA\\_GA\\_ATTACHMEN TS](https://disclosure.bursamalaysia.com/FileAccess/apbursaweb/download?id=99569&name=EA_GA_ATTACHMEN TS).

<sup>18</sup> Jame Barton, *Ncell backed by International Tribunal in Nepal Tax Row*, DEVELOPING TELECOMS, (Jan. 07, 2020), <https://www.developingtelecoms.com/telecom-business/operator-news/9066-ncell-backed-by-international-tribunal-in-nepal-tax-row.html>.

<sup>19</sup> Bibek Subedi, *LTO plans to conduct tax assessment of Ncell deal*, THE KATHMANDU POST, *Supra* note at 9.

<sup>20</sup> Prithvi Man Shrestha, *What Ncell Tax Dispute is All About*, THE KATHMANDU POST, *Supra* note at 13.

<sup>21</sup> Media Release, *Large Taxpayers Office confirms Ncell Fully Cleared of CGT with payment of NPR13.6 Billion*, (Jun. 4, 2017), [http://axiata.listedcompany.com/newsroom/Media\\_Release-\\_Ncell\\_June\\_4.pdf](http://axiata.listedcompany.com/newsroom/Media_Release-_Ncell_June_4.pdf).

<sup>22</sup> Pending cases, <https://icsid.worldbank.org/cases/case-database/case-detail?CaseNo=ARB/19/15>, (last visited August 27, 2020).

<sup>23</sup> Rajesh Bastola, *Nepal is ignoring a necessary International Arbitration at its own Risk*, THE KATHMANDU POST, (Nov. 11, 2019), <https://kathmandupost.com/columns/2019/11/11/nepal-is-ignoring-a-necessary-international-arbitration-at-its-own-risk>

<sup>24</sup> Pending cases, *Supra* note at 23.

<sup>25</sup> Bibek Subedi, *LTO plans to conduct tax assessment of Ncell deal*, THE KATHMANDU POST, *Supra* note at 9.

<sup>26</sup> Pending cases, *Supra* note at 23.

It is speculated that the Tribunal may be biased towards Axiata over Nepal because the transaction was based in the Netherlands and two arbitrators are from the global north and their decision may benefit the same region.<sup>27</sup> The ignorance of Nepal about the arbitration does not stop the proceedings as there are instances where *ex parte* awards have been given by ICSID.<sup>28</sup> Should Axiata and Ncell win, Nepal will have to reimburse a huge amount of money including tax, interest, and damages claimed, which is a substantial loss to the Nepali economy. If Nepal fails to reimburse, the Nepali market will not seem attractive to the foreign investors, which again is a loss to the Nepali economy.

Nepal could have challenged the arbitration by raising preliminary objections on the jurisdiction of the ICSID in this matter under Article 41 of ICSID convention. It could challenge Ncell's non-exhaustion of available local remedy like against the calculation of tax, lack of direct interest of Axiata UK in Ncell that prevents invoking the UK-Nepal Bilateral Investment Treaty(BIT), non-exhaustion of local remedies by Axiata UK before opting arbitration and the admission and payment of tax liability (though partially) by Ncell.<sup>29</sup> Furthermore, even when BIT was held applicable, it could be questioned whether owning Ncell through Reynolds qualifies as an investment of the UK under UK-Nepal BIT.<sup>30</sup> Since the proceedings took off despite Nepal's inaction, now Nepal only can defend itself in the arbitration.

### **The Root of the Issue**

The Ncell tax issue arose and lengthened till arbitration because of loopholes in national law, weaknesses in tax authorities, lack of international cooperation, and ambiguities in treaties. The issues are explained below with possible measures to cope with them.

#### Amendment in national law

In the era where businesses are able to avoid their taxes to lower the profits locally and shift the profits to lower-tax locations, laws must be amended to impose appropriate tax liability on them. The Income Tax Act of Nepal was drafted in 2002 which is almost 20 years ago. Since then, the international investment situation has drastically changed, leaving a pressing need for its amendment. In Ncell's tax issue, Reynolds was the controlling entity of Ncell but it was not registered in Nepal and hence not recognized by Nepali tax law. Telia Sonera, the seller, had the liability of paying capital gains tax as per the accepted principles but it was also not registered in Nepal. So, taking advantage of the inability of the government to inquire about it, it claimed the transaction to be offshore and successfully escaped. Though Ncell claimed to have no involvement

---

<sup>27</sup> Dr Matti Kohonen et al., *Trapped in Illicit Finance: How abusive tax and trade practices harm human rights*, *Supra* note at 15.

<sup>28</sup> Rajesh Bastola, *Nepal is ignoring a necessary International Arbitration at its own Risk*, THE KATHMANDU POST, *Supra* note at 24.

<sup>29</sup> Semanta Dahal and Vikas Mahendra, *Nepal has Strong Case on Ncell Arbitration*, NEPALI TIMES, (May 6, 2019), <https://www.nepalitimes.com/latest/nepal-has-strong-case-on-ncell-arbitration/>

<sup>30</sup> *Id.*

in the transaction, the court managed to hold Ncell liable for the tax opining that Axiata assumed all the outstanding liabilities of Telia Sonera along with its assets when it bought Ncell. Since Axiata is not registered in Nepal, Ncell was made liable as a subsidiary. Non-clarity of law requires court intervention in every dispute which makes the tax system unpredictable. Therefore, the law must be amended so as to clearly incorporate taxation relating to offshore transactions of assets in order to create a predictable legal regime.

#### Proactive actions of authorities

Along with amendment in law, Nepali tax authorities along with bureaucrats need adequate knowledge and competence on how to analyze and promptly deal with these complex tax issues. Whenever applicable, they must use their power of General Anti-Avoidance Rule under Section 35 of the Act to discard undesirable tax arrangement scheme employed by the businesses. While Nepal has been conducting investment summits to attract investors from around the world, it must also make sure that its market is attractive to potential investors by making its tax regime investor-friendly.

#### International Cooperation

A combined action at the international level is required in the field of taxation of offshore transactions. Multinational companies use various tax avoidance arrangements like creating shell companies in tax haven countries, engaging in treaty shopping to shift profit from resident countries to third countries without bearing tax liability. In 2015, the Organization for Economic Cooperation and Development (OECD) estimated that tax avoidance cost between USD 100-240 billion per year, or 4-10 percent of global corporate tax revenues.<sup>31</sup> Owing to the situation, under the OECD/G20 Inclusive Framework on Base Erosion and Profit Shifting (BEPS), over 135 countries are collaborating to take 15 actions to cope with tax avoidance strategies that exploit gaps and mismatches in tax rules, improve the coherence of international tax rules and maintain a more transparent tax environment.<sup>32</sup> Still, the international tax regime is largely governed by treaties and national laws. Therefore, there is a need for a global Convention to govern the issues which would help avoid inconsistency in the treatment of transactions.

#### Resolving ambiguities in Treaty provisions

DTAAs are used to govern tax involving nationals of two countries. Such agreements allow the nationals to pay taxes in either of the countries. But, DTAAs may allow companies to avoid paying capital gains tax like in the Ncell case where the parties invoked the Nepal-Norway DTAA to

---

<sup>31</sup> OECD, *OECD G20 Inclusive Framework on BEPS 2*, July 2018- May 2019, <https://www.oecd.org/tax/beps/inclusive-framework-on-beps-progress-report-july-2018-may-2019.htm>.

<sup>32</sup> OECD, *Understanding Tax Avoidance*, <https://www.oecd.org/tax/beps/>.

claim that no capital gain tax was payable.<sup>33</sup> Here, on the basis of Article 13 of the DTAA, Telia Sonera argued that impliedly the capital gains on shares are taxable in Norway only and it is not obliged to pay such tax in Nepal.<sup>34</sup> It escaped the liability and Axiata had to bear the liability. So, amending the ambiguities in BITs along with clarity on taxation of capital gains is imperative. One way as suggested by The Financial Transparency Coalition to the UN Tax Committee is to explicitly require payment of capital gains tax in the jurisdiction where assets are located as per company account and registries that must be publicly available.<sup>35</sup>

## Conclusion

In the highly debated issue, the Supreme Court took a bold step in taxing the buyer for capital gains tax securing revenue for the nation. Still, the issue did not settle there. Even after a reduction in the tax amount once assessed, Ncell went to ICSID for arbitration. It has paid the full due amount now but if the arbitration decision comes in favor of Ncell, it might be a huge financial liability for Nepal. The issue resulted mainly from legal loopholes. So, it must be resolved and the tax authorities must be made competent to take the required steps in levying tax where necessary. The international community must work together to enact a global tax convention to address required issues. The treaties entered into must be re-examined to eliminate any ambiguities. Nepal should take this case as a lesson to improve its tax regime and adopt changes to make the investment climate more attractive.

---

<sup>33</sup> Financial Transparency Coalition, *Submission to the UN Tax Committee ahead of the 20th Session of the Committee of Experts on International Cooperation on Tax Matters* (Jun. 15, 2020) 5, [http://www.un.org/development/desa/financing/sites/www.un.org.development.desa.financing/files/2020-06/CRP%206\\_FTC%20Submission%20to%20UN%20Tax%20Committee%20June-2020.pdf](http://www.un.org/development/desa/financing/sites/www.un.org.development.desa.financing/files/2020-06/CRP%206_FTC%20Submission%20to%20UN%20Tax%20Committee%20June-2020.pdf).

<sup>34</sup> International Monetary Fund, et al, *The taxation of Offshore Indirect Transfer- A Toolkit* 6, (Oct. 2018), <https://www.oecd.org/ctp/PCT-offshore-indirect-transfers-draft-toolkit-version-2.pdf>.

<sup>35</sup> Financial Transparency Coalition, *Submission to the UN Tax Committee ahead of the 20th Session of the Committee of Experts on International Cooperation on Tax Matters*, *Supra* note at 34.

## About Corresponding Author's



Mr. Madhab Raj Ghimire is Consultant for Infrastructure Law and Economics, PPP Law and Competition Law. Mr. Ghimire holds an LLM Degree in European Regulation of Network Industries from the University of Bonn, Germany. Mr. Ghimire is a visiting faculty member at Kathmandu University, Nepal. He is lawyer by profession and is an Infrastructure Legal Consultant for PSM Global Consultants P. Ltd and one of the founders of Center for Rule of Law, Nepal. Mr. Ghimire is continually consulting for the World Bank, Asian Development Bank and other National Government Agencies related to infrastructures in his home country and abroad. The book, Water and Energy Law, is coauthored by Mr. Ghimire and has published articles in national newspapers in the areas of infrastructure industries regulatory regime, investment, PPP and PSP for project development. In the past, Mr. Ghimire served as Chief-editor of Advocacy Legal Magazine in-and-around millennium, President of Center for Law and Justice and was Member-secretary for the Lawyers' Academy Committee, Nepal Bar Association.

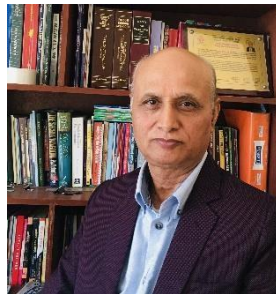

Dr. Narayan Ghimire is a Senior Advocate and practices at Supreme Court Nepal. He holds Doctor of Juridical Science (SJD) and LLM (Hon's) California USA, and MA LLB from Nepal. He was Former Member to the Commission for the diplomatic passport abuse investigating commission Nepal -2001 and Founding member and President of Centre for Rule of Law- Nepal. Dr. Ghimire has been invited for guest lecture in various Universities and frequently writes in legal journals. He has conducted various trainings on the constitution and human rights, legal aid, pro bono and tort law and known as one of the fine academicians and legal practitioner. He is also coordinating the committee on Tort Law for the Supreme Court Bar Association and has taken the responsibility of framing Legal Aid Guidelines for Nepal Bar Association. Dr. Ghimire is also involved as Pro Bono National Trainer for Nepal Women Lawyers International Training organized by Nepal bar Association, DLA Piper, UNDP and WLJH. Currently Dr. Ghimire is serving as Chairperson of Center for Rule of Law, Nepal.



Ms. Ronika Thapa is Associate at Neupane Law Associates. She holds a BBM, LL.B. Degree from Kathmandu University School of Law. She is working to specialize in corporate law with a special focus on investment and tax law. She has experience in assisting individual and institutional foreign investors in foreign investment deals and various transactional matters, including setting up joint venture companies. She also has experience in drafting commercial agreements. Ms. Thapa advises leading companies of Nepal in matters relating to corporate compliance, labor laws and day to day legal issues.

# **GOVERNANCE: A "MUST" TO REALIZE SUSTAINABLE DEVELOPMENT GOALS IN NEPAL**

**Er. Ravi Khanal**

Secretary, NEGAAS

Email: [ravikhanal2016@gmail.com](mailto:ravikhanal2016@gmail.com)

## **ABSTRACT**

Since the word governance is not directly included in the list of Sustainable Development Goals, stakeholders particularly planners, implementers and discussants in Nepal generally feel not obliged to pick it up in relation to discourse on SDGs. It has not only created a gap in pursuit of SDGs but also ignored a very important ingredient essential for manning the process of realizing the goals. It has resulted in deficiency in understanding and approaching the 17 goals with due respect for the linkage, mutuality and contrast which exist in sectors covered by the goals. No focused effort has been made to integrate governance with pursuit of goals individually or collectively. The country actually missed, during the past four years, an opportunity for preparing a bedrock which could have been instrumental in facilitating realization of the goals. All engaged in SDGs cannot afford to lose more time; they all should proceed and integrate governance with the goals individually or collectively.

## **KEYWORDS**

Governance, Sustainability-culture, Accountability, Localization, Transparency.

## **INTRODUCTION**

One theme that goes mostly missing in Nepal during conversation or practice related to Sustainable Development Goals (SDGs) is governance. Most familiar with what could be called the UN "blueprint to achieve a better and more sustainable future for all" by 2030 know well that good governance plays a significant role in pursuit, realization and sustainability of schemes undertaken for the SDGs. Yet they appear rather lost over the way of integrating governance into SDGs. Because of this, the country could not develop a dedicated guideline in this regard over the past four years when the country had a handy tool – federal practice – to facilitate most tasks under SDGs from the central level to those of provinces, and local governments.

This article intends to present general reflections on governance as a must to realize SDGs in the context of local levels of present day Nepal. In the process it sketches the frame of governance and

its application to the 17 goals. It underlines the need to place the theme of governance in public discourse for motivating people to understand governance beyond the periphery of management, administration and day to day operation. It stresses the need to take governance as a social process through which all institutions, government, non-government bodies, civil societies, action networks, and private sector entities are mobilized for a purpose through policies.

None questions the need to steer governance specifically to achieve goals individually or collectively. Problems emerge when those who handle governance or run the government get confused about the way to integrate governance into the SDGs. Further difficulty surfaces when those in government feel that the general day to day administration framework being pursued traditionally in the country would be enough for SDGs.

They appeared not ready to accept the broad framework of governance particularly its famous indicators represented by various values and practices. Each of the eight—rule of law, participation, consensus-orientation, accountability, transparency, responsiveness, effectiveness/efficiency, equitability and inclusiveness serves as a pillar of good governance. Yet those responsible for governance in Nepal could not pay attention to them properly; they did not have political will for them. What they did was simply adopting and pursuing whatever is convenient to them at the moment. Elected leaders, administrators in civil service, technocrats and implementers at three levels – federal, provincial and local - appeared motivated by their own discretionary way of managing things. They did not opt for the eight components of governance.

## **SUSTAINABLE DEVELOPMENT SECTORS**

All of SDGs could, in a sense, be termed as lists of human wishes. But on close analysis, each of them reveals, individually or collectively, the basics, which are essential for, continued existence of human life on mother earth. Each aims after ensuring, for humans, health, happiness and the conditions, which are instrumental in making the best use of knowledge, skill, creativity, talent and ability. The idea of not leaving anyone behind emphasizes inclusivity in the real sense of the term. This would be possible only if there is a provision for competent public institutions to guarantee equality, justice and peace for all in societies.

The phrase – Happy Nepalis, Prosperous Nepal – constitutes the current motto of Nepal. It cannot be accomplished without ensuring a situation for the fulfilment of the SDGs and avoidance of backwardness, under-development and inefficiency. The argument undoubtedly establishes the relevance between the two and offers yet another rationale for Nepal to pursue SDGs.

Planners in Nepal, expressing commitment to the SDGs, have prepared a scheme - the Status and Roadmap 2016-2030 - in this regard. The country's objectives of economic and social development also reflect the spirit and ideas of SDGs. The ongoing 15<sup>th</sup> Plan (2019-2024) stands witness to this fact. The 2015 Republican Constitution, besides guaranteeing rights, inclusivity and participation, has prepared a suitable mechanism – federalism with three tiers of government –central, provincial and local- for implementing programmes of SDGs from the top to the grass-root level.

Unfortunately, the COVID-19 pandemic and the multiple disruptions it caused in Nepali society for two years 2020 and 2021 in a row have produced an adverse impact on all plans, programmes and development schemes in Nepal. A number of challenges have cropped up on various fronts of development in the country. The value of governance is in reality being felt strongly at the moment in every sphere of national life and activities. Yet a way of embracing governance in all pursuits of development, SDGs and related activities has not yet been charted.

Political uncertainty is not allowing the country to focus on SDGs and governance. Most of the policies and programmes and budgets presented by various layers of government in federal Nepal for fiscal 2021-22 do not indicate any focused approach to SDGs. They do not indicate any plan to integrate governance with development activities.

## **RAY OF HOPE**

The change in government (on July 13, 2021) triggered by the Supreme Court's verdict and the subsequent backing by an impressive parliamentary vote of confidence for it has created hope for political and governmental stability for a year and a half. The new coalition ministry led by Prime Minister Sher Bahadur Deuba (Nepali Congress President) is expected to, among other things, pay attention to focus on governance, delivery of public services and SDGs. It has to do these things to justify its joining Singha Durbar during the mid-term of parliament and to demonstrate that it is more capable than the single communist-party (CPN UML) majority government under former PM Oli.

Policymakers of a new government would do well if they could adopt ways to end the pandemic disruptions and trend of Asare-Bikas (a Nepali language phrase which denotes undertaking development works in the last month of the fiscal year for fulfilling paper-works-formalities while ignoring sustainability and professional ethics). Although most governments (28 in 31 years) in the past were familiar with the bad trend, they were somehow compelled to preside over it. The financial irregularities which accompany Asare Bikas impact adversely all segments of the national economy. The same has been found to be instrumental in institutionalizing budgetary indiscipline.

Making the best use of the federal structure – central, provincial and local – including proper mobilization of budget and human resources in all three levels for development works covered under the SDGs could be the other agenda for the new government. Motivating all elected officials in three levels throughout 77 districts of 7 provinces for the great task under SDGs could initiate a collaborative environment for sustainability-works.

Integrating governance with the works related to development, sustainability and public service delivery also emerges as the task for the new government. Paying special attention to it would not only enhance the image of the new government but also add value to its socio-political capital.

If the new government could lay a professional backdrop for sustainable development works in the next 18 months, the country would have a sound bed-rock for building the superstructure required for realizing some of the SDGs remarkably by 2030.

The Election Commission emerged as a promising institution in Nepal because of its capacity to conduct single-day - election for local government for 753 municipalities spread over 77 districts of three different geographical settings – Terai, Hills and Himalayas. Viewed against the backdrop of a series of disruptions in matters of holding polls in the country in the past 32 years, the completion of local polls on May 13 could be termed a grand success, said a political analyst. "It has not only assured continuation of federal democracy for the next five years but also prepared the groundwork for further consolidating the structure of multi-party parliamentary democracy in the country at the grass-root level."

The care the EC took in updating (up to a voting day) voter's list and the manner in which it remained insulated from the adverse impact of the pandemic earned praise for it from all including 3.6 million new voters. The courage the EC mustered this time in asking former Prime Ministers and senior political leaders – male and female – to explain their violation of the election code of conduct has also been noted by poll observers as a promising exercise to ensure fair campaigning and conduct in polls. Despite all efforts, the EC could not scrutinize the election expenses and excesses some tried in poll campaigning. It has also to do a lot in the sector of voter education, maximizing participation and minimizing the number of invalid votes.

The total number of voters in May 13-local level elections, 2022, it might be recalled, stood at 17.7million, some 3.66 million more than in 2017. Of them 12.1 million (68.7%) cast their ballots to elect representatives for 753 units -293 urban municipalities and 460 rural municipalities. The number of invalid votes was 1.3 million. The figures point out the need to expand voter education effectively. Three political parties emerged effective in the polls: Nepali Congress won 329 local unit chief seats (43.8%); UML got a victory in 205 (27.3%) while the Maoist Centre prevailed in 121 seats (16.1%). The ruling coalition – NC, MC , CPN US, JSP and RJP – occupies 64% of seats compared to UML's 34%. The same is an indicator of justification for poll partnership.<sup>1</sup>

The victory of over a dozen independent candidates including four independent Mayoral candidates in Kathmandu (Balen Shah), Dharan (Harka Sampang Rai), Dhangadhi (Gopal Hamal) and Janakpur (Manoj Kumar Shah) has been considered as a challenge to major political parties with an impressive history and rich organizational network. According to one analyst they have to "immediately correct their flawed modus operandi" (The Annapurna Express, June 2-8, 2022 p.4).

The new experiments under independent candidates are being planned in the context of the forthcoming parliamentary and provincial polls towards the end of 2022. Buoyed by the recent

---

<sup>1</sup> The Election Commission information outlets, May-June, 2022

victory of independent candidates, some youths have decided to launch a campaign for independent candidates for parliament and provincial assemblies.

Swatantra Umedbar Abhiyan (Campaign for Independent Candidates) engaging a number of youths online or offline has been formed for the purpose. It will network with all those who offer or support independent candidacy throughout the country. Serious consultations regarding the same are currently taking place in different places, said a campaigner.

Women also did better in the local polls this time. Although their candidature, this time, was less than in 2017, the number of elected women has increased to 14,407 (41.21%) of the total elected 34,953 (The Kathmandu Post, May 28, 2022 p.1). Political dissidents who opposed parliamentary democracy for a long also participated in some form of the local elections and got varied success. Inspired by that they are also contemplating participation in the year-end federal parliamentary and provincial elections.

All the trends mentioned above indicate better times ahead for governance for sustainability for they appear to guarantee stability, which is key to both.

## **FOCUS ON LOCALIZATION**

Localization is essential for the realization of SDGs. It serves as a tool for strengthening the grass-root level of villages and cities, which are officially covered under the domain of municipalities and rural municipalities. Fulfilling SDGs without empowering them is simply not possible. The trend to sideline the issue is dangerous. In matters of both SDGs and governance, localization should not be overlooked.

Wards constitute the foundation of the federal structure envisioned by the republican constitution. It is important to make the wards develop, remain constantly conscious of governance, alert about sustainable development and sensitive to having efficiency in service delivery. Equally essential for the wards is the participation in a full-fledged manner and taking the ownership of whatever initiative is undertaken in the context of SDGs. The message should be comprehensible to all officials – elected or appointed or nominated – attached to the wards. It is after all their behaviour and response that determines how smoothly programmes for the realization of SDGs are planned, organized, implemented and monitored.

They should be familiar with the interlinkage of SDGs. The goals, as summarized by the official document of the National Planning Commission, happen to be "no poverty, no hunger, good health and well-being and quality education" and they require high-level public engagement. They are not something to dole out; special provisions should be made for making people understand them, participate in them and own them. Similarly, the mission of gender equality, clean water and sanitation, affordable and clean energy and decent work and economic growth is so associated

with the public way of life, public belief systems and public behaviour that there can be no overnight wishful change in them. They need a massive and regular input of information for appropriately sensitizing people about their importance and practice.

Undertakings such as industry, innovation and infrastructure, reduced inequalities, sustainable cities and communities and responsible consumption and production are actually complex of several components in public life. They demand various types of interventions for change. For this, it is urgent to have a regular flow of information to sensitize people, decision-makers and those who man the economy and those who preside over the power structure. Other objectives under SDG like climate action, life below water, life on land, peace, justice and strong institutions also remain unachievable unless people are made literate on them and motivated towards them. Information flow is the answer to this as well. Governance is another essential factor in this regard.

The 17th is a calling for partnerships for accomplishing the complex of SDGs. The sense of working together for common goals is a value that can only be developed through a carefully worked-out plan. The goal remains remote if it could not be backed by a robust governance scheme backed by an active communication system. It could be facilitated by a sound system of governance and information flow.

Noble ideas inherent in SDGs include high value and respect given to labour and all economic activities ranging from entrepreneurship, production, consumption and settlements. Values such as a sense of responsibility and working in a team are also given high priority. The broad goal of all these processes is to ensure a bright future by preserving planet earth and protecting the interests of human beings.

Various schemes should be developed for pursuing appropriate governance tools to drive the process of implementation of programmes towards the achievement of SDGs. The governance tools are applicable to all sectors related directly or indirectly to SDGs. They facilitate the process of prioritizing sectors and exploring intervention areas to address gaps, needs and duplications in the pursuit of SDGs.

## **STATUS OF LOCAL GOVERNMENT**

Local Governments in Nepal, on the four years of existence, are facing a number of problems particularly failure to deliver public services, maintain financial discipline, steer development works with a sense of sustainability and check corruption. They have neither been able to utilize properly the 22 rights allocated to them by the Federal Constitution nor assure stakeholders that their elected status is capable of making a significant difference in governance and performance.

Experts say the local bodies are in need of developing the political will to serve and acquire practical skills of governance.

Reports of scrutiny bodies - Auditor General Office, The Commission for Investigation of Abuse of Authority and Rastriya Satarkata Kendra (National Vigilance Centre)- expressed objections to financial irregularities and other shortcomings in the functioning of local bodies over the past two years. They pointed out flaws in revenue collection, expenditure, and pursuit of financial and administrative procedures. Other researchers also found in local bodies lack of order, accountability, consistency and transparency in planning, budgeting and use of financial resources.

The trend to drive development works towards quick popularity at the cost of sustainability and efficiency has resulted in the misuse of state resources. It has also challenged the national commitment – fulfilling the specified 17 targets under the Sustainable Development Goals by 2030. Ignoring the sustainability perspective in infrastructure development works is very dangerous, say sustainability experts. Moreover, the practice of not punishing those found engaged in financial indiscipline, abuse of authority and personalized use of public resources has encouraged corruption.

Local governments get financed through federal fiscal transfers (in the form of fiscal equalization, conditioning, matching and special grants). They also get their share of value-added tax and internal excise duty collections from the federal government. Moreover, they could also raise revenue locally as per the laws. A sum of Rs. 213 billion was allocated for the 753 local governments by the federal government through the fiscal year 2019-20-budget.

It might be recalled 36 local bodies did not get their accounts final- audited in the past fiscal year while 72 local bodies could not finalize their budget for 2019-20 in time. The absence of practice of mentioning limits in budgets and prescribing guidelines for using them has created a situation in which officers, decision-makers and implementers are free to use their discretion in budget-handling. There is a tendency to spend resources for unnecessary projects, luxurious purposes and finish development-resources any way (satirically phrased *Asare Bikas Kharcha* in the Nepali language) in the 12<sup>th</sup> month of the fiscal year. The Ministry of Federal Affairs and General Administration has warned them against such trends but the same gets usually ignored. A few former administrators fear the local bodies could land themselves in a risk zone if they do not correct their haphazard way of spending.

Stakeholders are not happy and their disappointment is being voiced through various forums – formal and informal. They feel very strongly disappointed about the local bodies failing to put up a statistical data benchmark – or detailed profile - for their areas of responsibilities- geographical or otherwise. Such a database could have been practically useful in various development works.

Participants at a seminar felt let down by the way local governments are functioning over the years<sup>2</sup>. Elected leaders, they wished, could have done much in the first year by way of formulating laws and generating development plans. Service delivery and implementation of those plans could have been the features of the second year. The third year could have witnessed a mid-term review and further intensification of the implementation of plans. The fourth year could be the year of further consolidation of all initiated in the previous years. The fifth-year could be utilized for completing work expected by people during past polls and preparing to approach voters for support once again.

Elected officials, in an attempt to defend themselves, say that they are learning the new system of federalism while facing a number of problems such as the absence of appropriate laws, non-cooperation from federal government and stakeholders, unavailability of resources, trained personnel and technical hands. They are committed to making the best use of the current fiscal year and the next one following it. "We will deliver before we approach people in next local polls," said a Mayor in a public forum.

The scenario presented above suggests the need to empower local bodies with governance skills. Those who manage them should know well about all eight components of good governance – participation, rule of law, transparency, responsiveness, accountability, equity and inclusiveness, consensus orientation, and effectiveness and efficiency. If the local bodies could adopt good governance tools the future will be more different, more optimistic and more service-oriented.

The same could be instrumental in realizing the goal of taking Singha Durbar (Central Secretariat) to the level of municipalities – rural and urban for working seriously towards the fulfilment of SDGs. Moreover the process would be particularly instrumental in delivering public services, driving development, identifying people's needs, bridging people and government and providing basic statistics.

The process will also enable local government to measure the outcome of all works performed by the government, establish a link between a ward and other levels – provincial and federal, serve as a platform for implementing policies, and programmes, monitor them with people's cooperation and ensure a standard of living and quality of life.

---

<sup>2</sup> Local Government: How Much Empowered? -:yfgLo ;/sf/ M slt ;an <\_ organized by Forum of Development Journalists (FODEJ), Nepal and Local Governance and Community Programme 2 on 16 Asar, 2076 (July 1, 2019) in Kathmandu

## **CONCLUSION**

Learning lessons from the past, stakeholders of SDGs and governance in Nepal should now adopt a focused approach to integrating governance with each goal individually or collectively. They should once again motivate the localization of SDGs and urge all 753 local governments to revisit SDGs and restart development works towards them. They should take up all eight components of governance as they discuss or practice agenda or programmes related to SDGs. Indifference towards SDGs and governance skills cannot be tolerated. The excuse in the name of political uncertainty and COVID-19 disruptions can also not be considered.

The federal mechanism established through constitution should be so utilized in the next fiscal year that the time lost for SDGs so far could be somehow made up and efforts for meeting the target of 2030 could be intensified with a sense of urgency.

## **REFERENCES**

- Adhikari, Rajendra, Local Government Institutions in Nepal : Status and Challenges, 2010
- Acharya, Keshav K., The Capacity of Local Governments in Nepal from government to governance and governability, 2018
- Bhusal, Thaneshwar, Understanding Local Government Coordination: As assessment of District Coordination Committees in Nepal, 2022
- Chaudhary, Deepak, Prospect of Good Governance and Human Development in Nepal, 2020
- Dahal, Girdhari, Democratic Practice and Good Governance in Nepal, 2017
- Diagnostic Study of Local Government in Federal Nepal, 2017
- Lamichhane, Bimal Prasad, Good Governance in Nepal: Legal Provisions and Judicial Praxis, 2021
- Media reports and interviews on SDGs-themes (2020-2021)
- Media reports (June, 2021) of policies, programmes and budgets of three tier governments for the fiscal year 2020-2022
- Nepal Government, National Planning Commission, Nepal's Sustainable Development Goals Baseline Report, 2017
- Pokhrel, Trilochan, Governance in Nepal: Context, Issues, and Challenges, Governance, NASC, 2015

Sharma, Kishor, Politics and Governance in Nepal, 2014

Sustainable Development Goals, Status and Roadmap 2016-2030, Government of Nepal, National Planning Commission UNDP – Nepal, SDG Report, 2017

The Constitution of Nepal, Government of Nepal, Part 3, 2072 B.S. (2015)



Er. Ravi Khanal is serving as Secretary of NEGAAS 2020-2022.

His education background: He holds a double Master Degree in Master in European Studies: Governance and Regulations from ZEI University of Bonn, Germany and Master in Sociology from Tri Chandra College, Tribhuvan University, Nepal. He completed his Bachelor of Electronic and Communication Engineering from Kantipur City College, Purbanchal University Nepal. Also, he got an opportunity to study in Fachhochschule Kiel, Germany.

Currently he is working as Manager in Kalpa Academy Center for Governance and Sustainable Development in the sector of governance and sustainable development activities. His areas of interest are in leadership, governance, sustainability and ICT the main instruments to change Nepali society.

Mr. Khanal was a GIZ Returning Expert for the year 2020-2022.

# Education, Science and Technology in the Context of Nepal and Germany: Some Perspectives<sup>1</sup>

**M. G. Treu**

Higher education in a formal sense is always linked to a language is the point I would like to start with. When it comes to learning unknown languages for the sake of transfer of knowledge then either the subject matter to be taught is presented in the language of the learner, or the learner learns the language of the teacher or it is taught in a third language known to both the teacher and the learner.

Since the languages in the countries like Germany and Nepal are not the same, the learner was made to learn the language of the teacher; the student had to learn German to the demanded extent in the respective area which means to the highest extent possible be it in the humanities, the natural sciences or the technical fields until a few decades ago and apart from very few exceptions.

Initially, all persons intending to study in Germany had to learn German to the degree which enabled them to pass the university German language entrance examination successfully and subsequently do all lecture hall and class room activities in German. Therefore, those who learned German at that time, as for instance, the biologist, former rector of TU, former president of Humboldt Club Nepal, former Vice-Chancellor of Nepal Academy of Science and Technology and founder member of Nepal German Academic Association (NEGAAS), Prof Dr Dayananda Bajracharya<sup>2</sup>, are excellent speakers of German and some of them liked it not only for professional purposes, but from their heart. When the topic of our conversation touched upon the teaching of German language courses at the Campus of International Languages (CIL) I remember Prof Bajracharya, while being the rector of TU, saying that he would like to come and

---

<sup>1</sup> This paper was read on the occasion of the International Conference on “Opportunities and Challenges of Management and Technology” held at MEGA National College, Kumaripati, Lalitpur, Nepal, June 8<sup>th</sup> and 9<sup>th</sup>, 2019.

<sup>2</sup> Valuable insights and experiences from his studies in Germany as the first Nepalese academic to receive a doctorate from a German University, as stated by the DAAD scholarship recipient himself, have been presented by Prof Dr Dayanand Bajracharya in his article “On a Scientific Journey to Germany” in: Treu, M. G. (Ed.) *Golden Jubilee Souvenir Fifty Years of Nepal- German Diplomatic Relations*, publ. by Steering Committee Celebrating 50 Years of Nepal-German Diplomatic Relations Nepal 2008 and the Embassy of the Federal Republic of Germany, pp. 36-42. The article was also published in the daily paper *The Kathmandu Post*, a few weeks later.

For a record with tables and plates of the overall scientific development in Nepal see Bajracharya, Dayananda; Bhujju, Dinesh Raj; Pokhrel, Jiba Raj (2006) *Science, Research, and Technology in Nepal* published by Royal Nepal Academy of Science and Technology, Unesco Office Kathmandu [173], Document code KAT-SC-2006/01, online document, Unesco. [unesco.org/ark:/48223/pf0000146117](https://unesco.org/ark:/48223/pf0000146117). Readers of Nepali can also profit from the author’s auto/biography *Baigyanik Goretomama [On the scientific path]* (BS 2075), which has already seen its 8<sup>th</sup> edition, and two collections of essays in the field of science, technology and education in Nepal, namely *Cetanako Yatra Jivanma Bigyan [Journey of the Mind. Science in life.]* (BS 2070) and *Andhyaroma ek kamti salai [A match in the darkness]* (2069 BS), all titles published by Ratna Pustak Bhandar, Kathmandu.

teach German at CIL in his later years or retired life. Unfortunately, death cut his life short before the Nepalese public could profit from his in depth knowledge and excellent command of his beloved German language.

Nowadays, the parameters have changed and it is not like in the late fifties or sixties any more. Education which was the child of poets, philosophers, explorers, writers and thinkers like Sokrates, Plato, Comenius, John Locke, Jean-Jacques Rousseau, Friedrich Schiller, Schleiermacher, Johann Gottfried Herder, Pestalozzi, Johann Friedrich Herbart, Wilhelm and Alexander von Humboldt<sup>3</sup>, Wilhelm Dilthey, Theodor Litt, Mahatma Gandhi, Einstein, Maria Montessori a. o. has *nolens volens* turned into a business commodity where states are also engaging themselves in. Together with the English language's slow but steady going to the lead in the field of science and technology after the end of World War II, English grew more and more important internationally, so that, as a consequence for cultivating German universities and institutions of higher education in the context of international co-operation and competition, at a large number of places of higher education, today, one can attend courses in most of the popular subjects in the natural sciences and the technical fields in English, too.

At present, higher education in Germany offers chances which were not available to students at the time of Prof Dr Dayananda Bajracharya. Formerly, being a citizen from a developing country one had to return to one's home country after finishing one's studies in Germany, now one can stay on provided one has found an employer who is interested in one's working for him/her.

Things have changed drastically through the last thirty, forty years. Cheap labour for the job market, highly qualified personnel in the academic and technical fields, migration from the Middle-East and Africa have changed the face of European society to a large extent from white to brown. This is what recent first time touristic visitors from Nepal to Europe stated as one of their impressions from their all Europe tour (marketed as "17 countries in 16 days"). To them, "the white man" (Nep.: Kuire), whom they had expected to see live in European countries, had hardly been visible.

Starting to co-operate with the Himalayan country Nepal, Germany soon realized that, besides humanitarian aid, education was the key to the desired development. Taking into account the prevailing stage of development and the wishes of its partner Germany had decided that along with the strengthening of Nepalese cultural identity an engagement in technical education was what the population of Nepal would benefit from most. The Nepal-German Manuscript Preservation Project sponsored by Deutsche Forschungsgemeinschaft (DFG) under the roof of the Nepal Research Centre, the German Volunteer Service (DED), the Bhaktapur Development Project and then the GIZ (formerly GTZ, Gesellschaft fuer technische Zusammenarbeit) arose from the will and

---

<sup>3</sup> For an appreciation of the life and achievements of Alexander von Humboldt perceived through Nepalese eyes see Bhattarai, Tribikram (2017) "Alexander von Humboldt – A Famous Naturalist of Germany" in: Regmi, Sandhya (Ed.), *NEGAAS's Professional Journal 2017*, publ. by Nepal German Academic Association, Kathmandu, pp. 140-146.

vision of early Nepal-German co-operation at the state level. The first technical training institution in the whole of Nepal came into existence through Nepal-German co-operation in the form of Thapathali Campus under the umbrella of TU. Later, the Industrial Training Centre at Balaju was added.

Soon after establishing diplomatic relations in 1958, a tiny Goethe Institute / Reading Room as a branch of the Max Mueller Bhavan New Delhi with its founder director Prof. Dr. Heimo Rau, South Asian art historian and long standing Director of Max Mueller Bhavans in India, was started at Jamal, Kathmandu. The German government, however, emphasized little on language and literature; it prioritized education in science and technical subjects, instead. This is clearly reflected in the scholarships granted by the German Academic Exchange Service (DAAD) where the humanities are hardly found, but predominantly subjects belonging to the natural sciences and the technological field.

In general, academic study courses were given through the offices of DAAD and technical training was given through the offices of Carl Duisberg Society (CDG), the Deutsche Stiftung fuer Entwicklungshilfe (DSE), through Invent and others subsequently. Technical and administrative personnel received education and training in Germany through governmental cooperation in many different fields. Among them there are subjects as diverse as carpentry, food technology, remote sensing, public administration or small business promotion. The biggest projects in Nepal German technical cooperation in the later phase, however, are the ones from the field of hydropower development where Marsyangdi and Middle Marsyangdi have become the backbone of Nepalese electricity supply.<sup>4</sup>

On the other hand, there are now many Nepalese students, more or less unheard of in the 50s and 60, who are in a position to finance their studies from their own resources. Their number amounts to roughly 1500 at present. Deplorable as it is from my personal perspective, hardly anybody from Nepal goes for a degree in German language, literature, philosophy or education. There are a few prominent cases like former ambassador of Nepal to Germany, Dr. Nobel Kishor Rai, who worked in the University of Kiel as postdoctoral fellow under Alexander von Humboldt Foundation grant or the present chancellor of the Nepal Academy of Fine Arts (NAFA), Mrs Ragini Upadhyaya who studied Fine Arts in Germany, but those examples are rather to be seen as exceptions to the general rule of preferred subjects among Nepalese students: They are natural science, medicine, engineering, IT, administration, management and a number of other trendy technical and environmental subjects. The study courses in management

---

<sup>4</sup> For a short description of Nepal-German co-operation and an enumeration of developmental projects see Dhakal, Surendra "Nepal-German Co-operation: Goals, Criteria, and Dimensions" in: Treu, M. G. (Ed.) *Golden Jubilee Souvenir Fifty Years of Nepal- German Diplomatic Relations*, publ. by Steering Committee Celebrating 50 Years of Nepal-German Diplomatic Relations Nepal 2008 and the Embassy of the Federal Republic of Germany, pp. 92-94.

find their spread growing in a number of new areas like, for instance, university management.

Finally, let us take a look into the future, since we now have strong and clear indicators telling where the trend will go. Results from the recently held European parliamentary elections show an overall wish of the voter not only in Germany, but more or less all over Europe for a more serious concern in cutting down the threat to the future existence of the whole of mankind due to climate change. The introduction of effective measures for the reduction of the carbon dioxide output globally is the need of the hour. The green parties went ahead and challenged the conservative majority in many countries. New forms of protests like the one called “Fridays for Future”, where the school girl Greta Thundal from Sweden together with her class mates stopped going to school on Fridays and demonstrated in the streets instead. These demonstrations set a drastic, but ultimately highly effective example to create an overall awareness for the urgent need to fight against the imminent dangers of global warming. Greta found followers and like-minded persons in Germany and other countries immediately and earned a huge media effect together with a welcome socialites’ support as well.

The recent exhibition put up by the German Embassy in cooperation with Tribhuvan University at Engineering Campus Pulchowk, Lalitpur on the possibilities and technical modalities of bringing about the “Energiewende” - a German term which stands for the shift in energy production leaving behind fossil combustion and nuclear power and turning towards renewable, clean energy like wind, water, solar power and other forms of energy production - is already a step into the direction of implementation efforts of the existential insight into the need of urgent concerted action in order to save the future of the planet earth as a place for human beings to breathe and live.

The conclusion from climate change and the Fukushima nuclear power plant accident in Japan have already changed and will further change the future path of technology in Germany and other parts of Europe. Environmental sciences and their substrates together with technological and educational demands derived from them will have an increased impact on society and its political decision making for the adequate and re-adjusted distribution of tax money and funds in building a free, but at the same time healthy, just and secure future where the donor of life, water, will flow for all and forever.

## References

Bajracharya, Dayananda. (2008) "On a Scientific Journey to Germany" in: Treu, M. G. (Ed.) *Golden Jubilee Souvenir Fifty Years of Nepal- German Diplomatic Relations*, publ. by Steering Committee Celebrating 50 Years of Nepal-German Diplomatic Relations Nepal 2008 and the Embassy of the Federal Republic of Germany, pp. 36-42.

-- (2069 BS) *Andhyaroma ek kamti salai*, [A Match in the Darkness] Kathmandu: Ratna Pustak Bhandar, Kathmandu.

--. (BS 2070) *Cetanako Yatra Jivanma Bigyan* [A Journey of the Mind Science in life] Kathmandu: Ratna Pustak Bhandar

--(BS 2075) *Baigyanik Goretoma* [On the Scientific Path] Kathmandu: Ratna Pustak Bhandar

Bajracharya, Dayananda; Bhujju, Dinesh Raj; Pokhrel, Jiba Raj. (2006) *Science, Research, and Technology in Nepal*, publ. by Royal Nepal Academy of Science and Technology, Unesco Office Kathmandu [173], Document code KAT-SC-2006/01, online document, [Unesdoc.unesco.org/ark:/48223/pf0000146117](http://Unesdoc.unesco.org/ark:/48223/pf0000146117).

Bhattarai, Tribikram. "Alexander von Humboldt – A Famous Naturalist of Germany" in: Regmi, Sandhya (Ed.) *NEGAAS's Professional Journal 2017*, publ. by Nepal German Academic Association, pp. 140-146.

Dhakal, Surendra "Nepal-German Co-operation: Goals, Criteria, and Dimensions" in: Treu, M. G. (Ed.) *Golden Jubilee Souvenir Fifty Years of Nepal- German Diplomatic Relations*, publ. by Steering Committee Celebrating 50 Years of Nepal-German Diplomatic Relations Nepal 2008 and the Embassy of the Federal Republic of Germany, pp. 92-94.

## **THREE AND A HALF DECADES OF NEGAAS JOURNEY**

**Dr. Roshana Shrestha**

**Prof. Dr. Chandra Bahadur Joshi**

### **Introduction**

In early 1980s, there were only a handful of scholars in Nepal who had studied in Germany. Among them Dr. Basanta Lal Shrestha was a prominent physician in Kathmandu who had undergone medical study in Albert Ludwig University, Freiburg/Beisgau, Germany. Upon his return, he had realized the need for an alumnus organization of Nepalese professionals who had studied in German universities, so that it could serve students aspiring to go to Germany for further studies while also effectively channeling the returnees in the development of the country. In 1981, he shared this vision with his friends late Prof. Dr. Dayananda Bajracharya and Dr. Chandra Bahadur Joshi, so that they all could together formulate a plan for establishing such an organization. Prof. Dr. Dayananda Bajracharya had earned a Doctorate Degree from Albert Ludwig University, Freiburg/Beisgau, Germany and was working in the Department of Botany, Tribhuvan University, Kathmandu, while Prof. Dr. Joshi had received his engineering from the Technical University Berlin, Germany and had been working as a Mechanical Engineer at Research Center of Applied Science and Technology (RECAST) at Tribhuvan University, Kathmandu.

The trio embarked on the mission. In 1983, with the help from other fellow returnees from German universities, they formed an Ad-hoc committee and assigned it the responsibility of suggesting an appropriate name for the association, drafting its constitution and registering it with the government.

### **Pre-Registration Activities:**

The Ad-hoc committee proposed a name as “Nepal German Academic Association (NEGAAS)” and drafted its constitution in cooperation with the then senior advocate and current Member of Upper Parliament Hon. Radheshyam Adhikari. It took five further years until the association could be registered with the government of Nepal in the year 1987. The Panchayat regime of that time did not easily register organizations with a name that included a foreign country’s name. This problem however did not stop NEGAAS from carrying out its activities during the pre-registration period. Meetings were held regularly and the alumni kept on working on accommodating new members, collecting information on Nepalese students studying in Germany and the ones applying for studies in German Universities.

### **Post-Registration Activities**

Immediately after the registration of NEGAAS an Executive Board was formed by its first Annual General Meeting in 1987 with Er. Chandra Bahadur Joshi, as the President and NEGAAS went into full swing. New formal relationships were created with Nepal-German related organizations including German embassy in Nepal, German Agency for Technical Cooperation, (GTZ today German Corporation for International Cooperation, GIZ), German Volunteer Services (GVS), German Academic Exchange Services (DAAD) office in New Delhi. Talk programs, seminars, workshops were held by inviting experts from Nepal and Germany from various walks of life. Annual news bulletins, brochures, booklet, souvenirs, journals etc. were published (see Annex 1). Honorary memberships were conferred to German Ambassadors (s. annex 2), welcome and farewell parties to German dignitaries were organized.

Social programs like annual picnics were organized. Meanwhile, the organization also dedicated itself to promote societal welfare programs like donations in cash and goods to 1988 earth quake victims in Dharan, East Nepal.

German Embassy also came forward to strengthen its cooperation with NEGAAS by inviting experts from among its members in their committee to select Nepalese candidates applying for German scholarships. The relationship between the German embassy and NEGAAS became stronger after its members were given audience by the visiting State Chancellor Dr. Helmut Kohl in 1987 recognizing the role that NEGAAS was playing in promoting the relationship between Germany and Nepal. On the occasion of German Chancellor's visit, articles of and interviews with the NEGAAS members were published in local Newspaper, and interaction programs were held in Nepal Television (NTV).

The second Executive Board was formed in 1998 with Prof. Dr. Dayananda Bajracharya, as the President in 1998.

### **The Ups and Downs of NEGAAS**

In June 30, 1999 NEGAAS lost its Vice-President and Founder Dr. med. Basanta Lal Shrestha\*. His untimely demise was a severe blow to both his family and NEGAAS. This event seriously affected NEGAAS' activities to the point that it even failed to call its Executive Board meetings, and also its Annual General Meeting. As a result NEGAAS could not get renewed with the government for years and its financial strength weakened significantly. Still worse, several active members who were frustrated by such a sad situation left the organization and no steps were taken to stop them.

---

\* If something other than this in relation to the Founder of NEGAAS is mentioned elsewhere, the readers are requested to correct it.

Unfortunately, this was also the time when other German returnees who did not have diploma had been trying to get memberships of NEGAAS, but due to the strict regulation limiting its membership only to the candidates possessing diploma certificates from German Universities, they were not provided the membership.

Even the German Embassy in Nepal was not happy about it. All these led to the formation of a new alumni organization of German returnees called Society of Nepal German Alumni (SONGA).

Later NEGAAS had changed its membership criteria to be more inclusive. According to the new criteria, those who had studied, got some training or done research work in Germany, they could be the member of NEGAAS. But it was too little and too late for the German returnees who had already joined SONGA. Dr. Novel Kishor Rai, the former Nepalese Ambassador to Germany, had led an effort to merge these two associations. But it was unsuccessful and NEGAAS had almost come close to dissolution.

### **Revitalization of NEGAAS**

In 2003, NEGAAS elected its third Executive Board, with Prof. Dr. Chandra Bahadur Joshi as the President. The main responsibility given to this Board was to revitalize this association. It was a herculean task, because NEGAAS was not renewed for last several years and the office of the Chief District Officer (CDO) was not ready to reregister it under the same name.

But with the combined efforts of the team, especially those of Prof. Dr. C. B. Joshi, Dr. Roshana Shrestha and Mr. Surendra Dhakal, the authorities got convinced and it was reregistered with the Government

under the same name "NEGAAS". Later the team also became successful in increasing its membership, strengthening the financial capability and re-establishes its credibility through different activities. The team remained in the office until February 2006.

In March 2006, the 18<sup>th</sup> Annual General Meeting elected a new team with Prof. Dr. Sekhar Gurung as the President followed by a team with Prof. Dr. Dilip Subba as the President in May 2008.

A very sad event occurred during that period. One of NEGAAS' most active, young and dynamic Executive Members Dr. Thaneshwor Gautam, who was always given responsibility to coordinate programs such as seminars and workshops and which he had done successfully for many consecutive years, suddenly passed away. His unfortunate and untimely demise caused NEGAAS a big loss and resulted in a complete halt of organizing workshops and Seminars by German Professors for two consecutive years.

In 2012, the 24<sup>th</sup> Annual General meeting elected a new team of NEGAAS with Dr. Roshana Shrestha as its President. Immediately following her tenure, the team with Mr. Surendra Dhakal as the President led NEGAAS from 2016-2018 and thereafter the team of Prof. Dr. Ramesh Kumar Maskey as its President from 2018-2020. From 2021 onwards a new team with Prof. Tanka Nath Dhamala as its new President has been leading this association.

The composition of teams and their major activities are listed in annexes 3 and 4.

### **Major Outcomes of NEGAAS Activities**

NEGAAS has persisted despite the ups and downs in its three and half decades primarily due to the dedication of its founders, members, executive teams, friends and good wishers of NEGAAS. It thrived under the leadership of the two most active secretaries - Mr. Surendra Dhakal and Ar. Rupesh Shrestha - who successfully navigated NEGAAS through the challenges and obstacles creating a successful forum where all the academicians trained in Germany could come and work together to fulfill its objective including strengthening the relation between Nepal and Germany, and assist people studying and working in various sectors as and when needed.

The great achievements made in the past has resulted into ever growing friendship with the German Embassy in Nepal, German Academic Exchange Services (DAAD) and many other Nepal German related organizations in Nepal and abroad. With this it has become easier for NEGAAS to organize increasing number of events for the welfare and benefit of several people from all walks of life in both of the countries.

From the series of talk programs, trainings, seminars, workshops, exhibitions etc\* held in the past by inviting noble laureates, renowned professors and academicians from both the countries, a number of people in government and non-government sectors in Nepal has been benefitted. These activities have established its credibility in Nepal and have attracted many members.

(\*Except the talks delivered by NEGAAS members and other local academicians all other programs were funded by DAAD)

### **Future of NEGAAS**

NEGAAS is a self-supported non-profit organization funded solely through its membership fees which are low. Because of a lack of a strong revenue source, it has not been able to establish its own dedicated

office building from where central coordination of its activities could be maintained. Despite this apparent weakness NEGAAS has been successful in carrying out a lot of activities of public benefit. It boasts of its membership with the highest numbers of post graduate degrees including Humboldt Fellows. NEGAAS holds a bright future by further coordinating and channeling the members' expertise for the development of the country and forging a fruitful relationship with other related organizations in Nepal and Germany promoting bilateral relationship and social welfare.

Meanwhile NEGAAS is privileged to have two DAAD Research Ambassadors, Prof. Dr. Ramesh Kumar Maskey and Prof Dr. Tanka Dhamala and two young DAAD Ambassadors, Ar. Rupesh Shrestha and Er. Sabina Khatri.

NEGAAS is currently being led by Prof. Dr. Tanka Nath Dhamala. The plans and programs put forward by the new team and the ways they are being implemented show a great hope for the future of NEGAAS.

### **References-**

1. Joshi, Chandra Bahadur, "Twenty Five Years of Nepal German Academic Association (NEGAAS)", NEGAAS Journal, Silver Jubilee Special Issue, December 2014, Kathmandu, Nepal.
2. <https://photos.app.goo.gl/GecTNPBqaVdjAQw18>)
3. Minute books of NEGAAS executive board meetings
4. NEGAAS News Bulletins
5. [www.negaas.org.np](http://www.negaas.org.np)

### **Annex 1: NEGAAS Publications:**

1. Interviews with and articles by NEGAAS executive members on the Education Systems in Germany, published in Rising Nepal in 1987
2. A booklet on “Alternative Energy Technologies in Nepal” by Dr. C. B. Joshi, published in collaboration with Goethe Institute, Kathmandu, 1987
3. NEGAAS News Vol. 1, No. 1, September, 1994 - Vol. 16, No.1, November 2018?
4. NEGAAS Souvenir Issue, 2011
5. 25 Years of NEGAAS, Silver Jubilee Special Issue, December 2014
6. 29 Years of Nepal German Academic Association, NEGAAS’s Professional Journal 2017
7. NEGAAS Journal 2019, published on the "Occasion of 60 Years of Diplomatic Relations - 60 Years of Friendship”, Sept 2019

### **Annex 2: List of Dignitaries Receiving Honorary Membership of NEGAAS**

1. H. E. Dr. Klaus Barth, German ambassador to Nepal
2. H. E. Franz Erwin Ring, German ambassador to Nepal
3. H. E. Verena Graf von Roedern, German ambassador to Nepal
4. H. E. Franz Myeke, German ambassador to Nepal
5. H. E. Mathias Meyer, German ambassador to Nepal
6. H.E. Roland Schaeffer, German ambassador to Nepal
7. Prof. Dr. Klaus von Klitzing, Director of Max Planck Institute for Solid State Research, Stuttgart and Nobel Laureate.

### **Annex 3: List of Ad-hoc Committee and Executive Boards**

#### **Ad-Hoc Committee (1983)**

1. Prof. Dr. Chandra Bahadur Joshi - President
2. Er. Ashok Ratna Tuladhar - Vice-President
3. Prof. Dr. Dayananda Bajracharya - member
4. Dr. med Basanta Lall Shrestha - member
5. Er. Binaya Kushle- member

#### **First Executive Board (1987 – 1998)**

1. Prof. Dr. Chandra Bahadur Joshi - President
2. Er. Ashok Ratna Tuladhar - Vice-President
3. Prof. Dr. Dayananda Bajracharya - member
4. Dr med. Basanta Lall Shrestha - member
5. Er. Binaya Kushle - member
6. Dr. Roshana Shrestha - member
7. Er. Narendra Bhupal Malla - member

#### **Second Executive Board (1998 – 2003)**

1. Prof. Dr. Dayananda Bajracharya - President
2. Dr. med. Basanta Lall Shrestha - Vice-President
3. Er. Jitendra Gurung - member Secretary

4. Er. Sandhya Regmi - member Treasurer
5. Mr. Santosh Bikram - member Shah
6. Dr. Shekhar Gurung - member
7. Dr. Pradeep Bhattarai - member
8. Prof. Dr. C.B. Joshi - member
9. Dr. Roshana Shrestha - member
10. Er. Ashok RatnaTuladhar - member
11. Er. Binaya Kushale - member
12. Er. Narayan Bahadur Shrestha - member
13. Er. Hari Kumar Shrestha - member
14. Er. Rishi Shah – member

#### **Third Executive Board (2003 – 2006)**

1. Prof. Dr. Chandra Bahadur Joshi - President
2. Mr. Santosh Bickram Shah- Vice-President
3. Mr. Surendra Dhakal – Secretary
4. Dr. Shashi Shankar Rajbanshi - Treasurer
5. Er. Rishi Shah - member
6. Dr. Roshana Shrestha - member
7. Er. Ashok Ratna Tuladhar - member
8. Dr. Tribickram Bhattarai- member
9. Er. Hari Kumar Shrestha - member

#### **Fourth Executive Board (2006– 2008)**

1. Prof. Dr. Shekhar Gurung - President
2. Er. Rishi Shah - Vice-President
3. Mr. Surendra Dhakal - Secretary and
4. Dr. Roshana Shrestha - Treasurer
5. Prof. Sharada Shrestha - Member
6. Dr. Tribikram Bhattarai - Member
7. Dr. Thaneshwor Gautam - Member
8. Dr. Tanka Dhamala - Member
9. Mr. Hari Kumar Shrestha - Member
10. Mr. Mahesh Gongol - Member
11. Mr. Ashok Tuladhar - Member
12. Dr. med. Anil Bahadur Shrestha - Member
13. Dr. med. Shankar Suri - Member

#### **Fifth Executive Board (2008– 2012)**

1. Prof. Dr. Dilip Subba - President,
2. Dr. Roshana Shrestha - Vice- President,
3. Mr. SurendraDhakal - Secretary and
4. Dr. med. Anil Bahadur Shrestha - Treasurer
5. Mr. Rishi Shah - Member

6. Dr. Thaneshwor Gautam - Member
7. Dr. Narayan Adhikari - Member
8. Dr. Shankar Prasad Suri - Member
9. Dr. Tribikram Bhattarai- Member
10. Er. Ashok RatnaTuladhar- Member
11. Er. Nitesh Shrestha - Member

#### **Sixth Executive Board (2012– 2016)**

1. Dr. Roshana Shrestha - President
2. Dr. Saroj Krishna Shrestha – Vice-President (2012-2014)
3. Dr. Tanka Nath Dhamala - Vice-President (2014-2016)
4. Mr. Surendra Dhakal - Secretary
5. Prof. Dr. Jyoti Devkota – Treasure
6. Dr. RameshworAdhikari –Joint Secretary
7. Prof. Dr. Tulasi Pathak – Member
8. Mr. Yubaraj Bhusal – Member
9. Mrs. Sharada Shrestha – Member
10. Mr. Ganga Datta Nepal – Member
11. Er. Ashok RatnaTuladhar – Member

#### **Seventh Executive Board (2016– 2018)**

1. Mr. SurendraDhakal - President
2. Er. Narendra Bhupal Malla - Vice-President
3. Dr. Rajendra K.C. - Secretary\*
4. Sharada Shrestha - Treasurer
5. Prof. Dr. Tulsi Pathak - Member
6. Prof. Dr. Novel Kishwor Rai - Member
7. Prof. Dr. RameshworAdhikari - Member
8. Er. Sushma Bajracharya - Member
9. Dr. Samir Shrestha - Member
10. Er. Sandhya Regmi - Member
11. Babita Poudel – Member

(\*After some time Dr. Rajendra K.C. was transferred to West Nepal and President Surendra Dhakal himself took over the responsibility of the Secretary, Dr. K. C. for the rest of his tenure).

#### **Eight Executive Board (2018 – 2020)**

1. Prof. Dr. Ramesh Kumar Maskey - President
2. Er. Sandhya Regmi - Vice-President
3. Ar. Rupesh Shrestha - Secretary
4. Er. Sabina Khatri - Treasurer
5. Prof. Dr. Tribikram Bhattarai- Member
6. Dr. Rajendra Joshi- Member
7. Dr. Babita Poudel- Member
8. Ar. Sharmila Shrestha - Member

9. Er. Sushma Bajracharya - Member
10. Mr. Rajendra Kumar Karki - Member
11. Mr. Simon Kumar Shrestha – Member

#### **Annex 4: Major Activities**

##### **Major Activities (1998-2003)**

1. An official get-together with Dr. Roman Herzog, the then president of Germany in Bhaktapur during his state visit to Nepal in the year 1996.
2. Invitation to German Nobel Laureate Prof. Dr. Klaus von Klitzing in the year 2009 to deliver a talk on “Effects of Climate Change and Importance of Alternative Energy Sources”. On this occasion, the NEGAAS members had an interaction with him on his work on integral Quantum Hall effect.
3. Publication of first NEGAAS journal, a copy of which was handed over to the visiting German President as well.
4. Conferring honorary membership to highly intellectual academicians and diplomats from both Nepal and Germany.

##### **Major Activities (2003 – 2006)**

1. A two day long exhibition on “Einstein and His Contribution to Science and Mankind”
2. Organization of Talk Program on "Contribution of Einstein for the Development of Science and Mankind",
3. Participation in an interaction program on "Einstein’s contribution to research and to the development the mankind" broadcasted by Nepal Television,
4. Organization of a Nation-wide Essay Competition on Einstein Contribution to Science and Mankind, and
5. Publication of articles on Einstein by NEGAAS members in local Newspaper throughout the year 2000.

(These programs were held to celebrate the "Einstein Centenary" throughout the year 2005 on the occasion of the publishing of "Einstein's Theory of Relativity". Among them the first program was launched at the National Academy of Science and Technology (NAST) under the financial support of DAAD. The program was a joint initiative of NEGAAS and the Federal Government of Germany).

##### **Major Activities (2006– 2012)**

1. On the occasion of 50 years of Nepal German Diplomatic Relation, NEGAAS, as one of the member organizations of the steering committee, coordinated in collaboration with the Embassy of the Federal Republic of Germany to:
  - mint a commemorative coin of Rs.1000.00
  - print postage stamp and
  - publish a souvenir aimed at celebrating 50 Years of Nepal German diplomatic relations in the year 2008.
2. Under the successful coordination of Executive Member Dr. Thaneshwor Gautam and his Social Science Research Foundation (SOSREF) :
  - Talk program on “Thinking like a Social Scientist: learning from the Advanced Research Tools”, and

- two days Seminar cum Workshop on “National Identity and Inter-group Conflict: Causes and Intervention”\*.
- Talk Programs, Workshops on Disaster Management and Seminar on Emergency Planning.

### **Major activities (2012-2016)**

1. A four days seminar on “Emergency Mitigation Using Optimization and Simulation Methods” with Prof. Horst W. Hamacher, Dr. Marc Goerigk (both from University of Kaiserslautern), and Prof. Dr. Gerta Koester (Munich University of Applied Sciences).
2. A workshop on “Learning by Interactive Knowledge Channels between the University and its Environment” with Prof. Yvonne Zajonzt from the Cooperative State University Baden-Württemberg.
3. Seminar on “Nutrition today: A Struggle between Obesity and Malnutrition”. The principal Resource Person was Ms. Barbara Bjarnason, Nutritionist, Germany.
4. Talk programs on:
  - Nepal in Nuclear Age
  - Engineering Education and Research in Nepal
  - Nano Technology
  - Conflict Management and Peace and Development, and
  - Mind Management

---

\*Speaker of House of Parliament, Mr. Shubhas Nemwang and the Ambassador of Federal Republic of Germany, Her Excellency Verena Graefin von Roedern had graced this event as Chief Guest and Guest of Honor respectively.

The first three events were financially supported by DAAD, University Grant Commission (UGC) Nepal, National Planning Commission and some colleges of Kathmandu and Bhaktapur.

### **Major activities (2016-2018)\***

1. published "NEGAAS Professional Journal (2017)" to mark its 29<sup>th</sup> AGM.
2. conducted three days workshops on "Migration in Nepal (Long Distance Migration & Environment Changes) in Kathmandu from 21-23 July 2017. It was sponsored by DAAD. The resource person was Prof. Dr. Beatrice Knerr of University of Kassel, Germany.
3. Donated 800.000,-.Rupees to Bhumi Devi MadhyamicVidhyalaya, Talakhu, Nuwakot to reconstruct its building completely destroyed by the devastating earthquake of 2015 A. D.
4. participated in the Sixth Asia Pacific Conference of Young Scientists held in Park Village Resort, Budhanilkantha, Kathmandu.
5. participated in the "Workshop on Blended Learning Program on Start-Up Entrepreneurship" jointly organized by German Alumni Association Nepal (GAAN) and giz (October 21, 2016).

\* A period of post earthquake and trade embargo

### **Major activities (2018-2020)**

1. participated in a number of events in Nepal and Germany.
2. signed two MoUs for the first time in its history:
  - the one with GZK with the purpose of promoting academic exchange programs and making NEGAAS more familiar to German diplomatic circles and external organizations including the other alumni organizations and
  - the second one was with Association of Nepalese Alumni from Australia(ANAA) with the aim of collaborating each other on activities ranging from academic, technical, social, cultural, diplomatic engagement and development-related topics
3. attended the events like "Celebration of 60 years of Nepal German Diplomatic Relations" and "Germany Day".
4. started together with German Embassy the counseling for postgraduate and Ph. D. scholars at GZK going to Germany for further studies under DAAD scholarship.
5. started a new session called "Meet the Alumni" in collaboration with GZK.
6. participated together with Goethe Zentrum Kathmandu and German Embassy in the " Everest Hackathon 2019 " event.
7. participated as one of the collaborators in the webinar "World Science Day 2020" organized by Renewable Energy Confederation of Nepal (RECON).
8. participated in the webinar "Science Diplomacy in the 21<sup>st</sup> Century".
9. donated fifty thousand Rupees to Corona Virus Pandemic Prevention, Control and Treatment Fund.
10. distributed educational materials to the students of marginal families studying in Shree Dhara Primary School of Pokhara, during Pandemy.
11. held a short course on writing a scientific proposal at RECAST with Joern H. Kruhl, Prof. of Technical University, Muenich, Germany, as the resource person.
12. donated fifty thousand Rupees to Kirtipur Municipality on April 24th 2020 to buy essential items for students at Kirtipur suffering financially from the Corona virus crisis.
13. published NEGAAS JOURNAL 2019 on the occasion of 60 years of Diplomatic Relations

# Alexander von Humboldt Foundation

Strengthen Germany as international research location

## Tribikram Bhattarai

Humboldt Research Ambassador

Nepal

## History

Alexander von Humboldt is a world famous natural scientist of 18/19 century. He explored the unexplored natural resources (Flora, fauna, geography and geology) of central America. After his death in his name Alexander von Humboldt Stiftung fuer Natureforschung und Reisen (Alexandervon Humboldt Foundation for Nature Research and Travel), Berlin was established in 1860. At that time the foundation provided support to German scientists to do research in other countries. The foundation suffered many ups and down in its history due to economic recession and world wars.

The foundation of present structure was established by the Federal Republic of Germany on 10 December 1953 to support young academicians in their study and research. Werner Heisenberg, the 1932 Nobel Prize Winner in Physics, became the first President of the Foundation. Headquarter of the Foundation is located in Bonn-Bad Godesberg, Germany. In total 78 Applicants with Bachelor's and Master's degree of 35 countries were granted fellowship first time in 1954. The number of fellowships increased in following years. The Foundation started supporting to build guest houses and International Meeting Centers in university towns of Federal states from 1963 to facilitate the stay of foreign academician selected for the fellowships. Due to this initiative, such guest houses are found now a day in all university towns of Germany.

In 1965 the purpose of the Foundation was redefined and started to provide opportunities for highly-qualified young academics to carry out research project in Federal Republic of Germany. Thus the Foundation works to make Germany as a favorable research location through international research exchange and started promoting mainly post-doctoral researchers. It sponsors scientist and scholars of all academic discipline of all nationality. The Humboldt fellows are known as Humboldtians. There are more than 30,000 Humboldtians from all over the world, of which more than 30 are Nepalese Humboldtians.

Presently, the Foundation mainly supports by sponsoring postdoctoral research fellowships. From 1985 the fellowships is extended to include research awards and Alexander von Humboldt professorship.

In 1996 special fellowships like Georg Foster Research fellowship was established for postdoctoral researcher from transition and developing nations including Nepal. To address the growing

worldwide problem of climate change from 2009 International Climate Protection Fellowships is started for prospective young climate experts mainly from transition and developing countries. Similarly in 2012 the Georg Forster Research Award was established for researchers from developing countries.

## **Sponsorships**

The Alexander von Humboldt Foundation (AvH) is established to promote academic cooperation between top-flight scientists and scholars from abroad and from Germany. Presently it grants more than 700 research fellowships and research awards annually mainly to academics from natural sciences, mathematics and the humanities. Through the grants researchers from all nations come to Germany to work on a research project they have chosen together with a host and collaborative partner of German institution. The scholars are free to choose their research topics and academic host or collaborative partner in Germany. The foreign researchers can choose their collaborative partner from 100 universities of Germany, 86 Max Planck Institutes, 68 Fraunhofer Institutes and 18 Helmholtz Centers. AvH Foundation also funds German scholars to go anywhere in the world to work on a research project with a collaborative partner abroad through the Feodor Lynen Fellowships. The collaborative partner must be a Humboldt fellow or a member of the Humboldt Network abroad.

The AvH Foundation works to promote international cultural dialogue and academic exchanges. The efforts of the foundation are to develop Germany as an international research location and to strengthen its position in global competition. This it tries to achieve through its different sponsorship programs to foreign and German academics. There are no quotas for the scholarships, neither for countries, nor for academic disciplines. There is no discrimination for races, gender and religion. The selection committees comprise academics from all disciplines and all its members make independent decisions. The decisions are based solely on the applicant's academic record. In all selections by AvH Foundation always excellence of candidates prevails. Thus the AvH Foundation supports the academics, not projects.

The Fellowships and awards of the Foundation are considered to be among the most prestigious awards in Germany. The Humboldt fellows are known as Humboldtians. Of the more than 30,000 Humboldtians from over 140 nations of the world, 56 are Nobel laureates.

## **Sponsorship programs**

AvH Foundation supports the research works of academics of all nations through its various sponsorship programs. The fellowships and awards are suitable to all academics, from young postdoctoral researchers at the beginning of their research careers to experienced researchers or world leaders in their research area. Followings are the major programs of the Foundation.

### **A. For Postdoctoral Researcher**

### **1. Humboldt Research Fellowship:**

This fellowship started from 1965 is for postdoctoral researcher with above and average doctoral degree with independent research experiences documented by recognised academic publications, preferably in international journals. The candidate must have completed the doctoral degree within the last 4 years of application. Applicants are responsible for choosing their own host and planning their own independent research plan. He/she should apply with research proposal with approval of host /collaborator in Germany. Details of the research outline and the timetable must be agreed with the prospective host before the application is made. The fellowship is for 6-24 months. The success of the application is determined by applicant's academic quality.

### **2. George Forster Research Fellowship**

The fellowship is named after an 18<sup>th</sup> century naturalist and journalist Johann George Adam Forster. It was established in 1996 to support researchers from transition and developing countries. Humboldt Foundation makes a list of qualified nations among the developing countries. Only the candidates from the developing countries present in the list of AvH are eligible to apply for this fellowship. Other eligibilities of candidates for this grant is similar to Humboldt Research fellowship

### **3. Feodor Lynen Research Fellowship**

This is a postdoctoral research fellowship for German going abroad to carry out long-term research at host institutes outside Germany. The foreign host must be a humboldtian, Humboldt alumni or a member of the Humboldt Network abroad. The programme is open to all disciplines. All other criteria are similar to Humboldt Research Fellowship.

The AvH Foundation expects the contribution of host institute to contribute in financing the research fellowship. However, host institutes in developing and emerging countries are not required to make a financial contribution.

## **B. For Junior Research Group Leaders**

### **4. Sofja Kovalevskaja Award**

This award is to build and head own junior research group at university or non-university research institutions in Germany. The award is given to foreign young researcher with above average doctoral degree within last 6 years with research publications in internationally recognized journals or in other equivalent publications. German scientists and scholars can apply if their habitual place of work and residence has been located abroad for at least five years. Candidates with outstanding academic achievements can apply with a group research proposal of their own choice and approval of host/collaborator. The sponsorship is for 5 years. The award winners each receive a total of €1.65 million. The Humboldt Foundation particularly welcomes applications from qualified, female junior researchers. The award winners should concentrate on the high level, innovative research of their own choice in Germany, so that the internationalisation of research in Germany is strengthened.

## **C. For Experienced Researcher**

### **5. Humboldt Research Fellowship**

Researcher with above average doctoral degree completed within the last 12 years can apply for this fellowship. The applicant should have already made own academic profile proved by publications in international journals or other equivalent publications. Applicants must submit research proposal and host approval. The fellowship is for 6-18 months. Other criterion fixed for Humboldt research Fellowship also apply here.

### **6. George Forster Research Fellowship**

All criteria for this fellowship are like Humboldt Research Fellowship for experienced researcher but this fellowship is only for researchers from transition and developing countries.

### **7. Feodor Lynen Research Fellowship**

This fellowship is for German researcher going abroad. The criteria for this fellowship are similar to Humboldt research fellowship for experienced researcher. The foreign host here should be a humboldtian or a member of the Humboldt Network abroad.

## **D. For international Researchers**

### **8. Friedrich Wilhelm Bessel Research award**

This award is for candidate with above average doctoral degree completed within the last 18 years and must have internationally visible academic achievements. Such candidate should be nominated by his/her German host. The award is for research stay in Germany which is of Euro 45,000. The AvH Foundation annually awards approx. 20 **Friedrich Wilhelm Bessel Research Awards** to internationally renowned academics from abroad, in recognition of the outstanding academic performance of the researcher.

### **9. Humboldt Research Award**

The candidates are nominated by German host working at universities or other research institutions in Germany. Self-nomination is not possible. The award is given to researcher with outstanding academic achievements. The award amount is 60,000 Euro and it is for research stay in Germany. The award winners are invited to undertake research projects of their own choice in Germany, in cooperation with German colleagues from their disciplines. The period of award is approx. 6-12 months which can be divided up into shorter periods of time.

The Alexander von Humboldt Foundation grants up to 100 **Humboldt Research Awards** annually to internationally eminent academics from abroad in recognition of their entire academic record to date. .

### **10. George Forster Research Award**

This award is similar to Humboldt Research Award, but it is awarded to researchers from transition and developing countries. A candidate for the Georg Forster Research Award should be nominated by an established academic employed by a university or research institution in Germany. This award was launched first time in 2012.

The AvH Foundation grants up to four Georg Forster Research Awards to internationally established researchers of all disciplines from developing and transition countries in recognition of their entire academic record. The award amount is €60,000. In addition, Award winners are invited to conduct a research project of their own choice in Germany in close collaboration with a German specialist colleague. The project duration is of about six to twelve months may be divided into segments. The objective of inviting award winners to Germany is to contribute to the long-term promotion of outstanding scientific multipliers in transition and developing countries whose research will contribute in improving living conditions in their own countries. To support the collaboration, the Humboldt Foundation may grant additional funding of up to €25,000, particularly for participating in scientific conferences, additional material resources, e.g., specialist literature and scientific equipment for the nominee’s own institute, as well as for involving junior researchers.

**Tab. Overview of the major programs of the Foundation**

<b>Programs</b>	<b>For Academics from abroad</b>	<b>For Academics from Germany</b>
<b>Postdoctoral researchers</b> (up to 4 years after completion of doctorate)	<ul style="list-style-type: none"> <li>• Humboldt Research Fellowship</li> <li>• Georg Forster Research Fellowship</li> </ul>	<ul style="list-style-type: none"> <li>• Feodor Lynen Research Fellowship</li> </ul>
<b>Junior research group leaders</b> (up to 6 years after completion of doctorate)	Sofja Kovalevskaja Award	
	<ul style="list-style-type: none"> <li>• Humboldt Research Fellowship</li> <li>• Georg Forster Research Fellowship</li> </ul>	<ul style="list-style-type: none"> <li>• Feodor Lynen Research Fellowship</li> </ul>
	<ul style="list-style-type: none"> <li>• Max Planck-Humboldt Research Award</li> </ul>	
	<ul style="list-style-type: none"> <li>• Friedrich Wilhelm Bessel Research Award</li> </ul>	
<b>Internationally renowned academics</b>	<ul style="list-style-type: none"> <li>• Humboldt Research Award</li> <li>• Georg Forster Research Award</li> <li>• Alexander von Humboldt Professorship</li> </ul>	
<b>Prospective leaders</b>	<ul style="list-style-type: none"> <li>• German Chancellor Fellowship</li> <li>• International Climate Protection Fellowship</li> </ul>	

The Humboldt Foundation particularly encourages the nomination of qualified female researchers.

### **11. Anneliese Maier Research Award**

This award is given in Humanities and Social sciences for collaborative research. The awardees' must have internationally outstanding academic achievements and must be nominated by a German host. The award amount is of Euro 250,000 and it is for academic cooperation over 5 years.

### **12. Alexander von Humboldt Professorship**

The candidate having internationally outstanding academic achievements should be nominated by a German University via the rectors or presidents of the respective university and, where relevant, the academic directors or boards of non-university research institutions. He should work in an institution in a German university. The nominating institution must describe how it is going to ensure that the nominee's future academic work will contribute to developing or establishing research focus areas in his/her discipline at the receiving institution. Furthermore, nominators must explain their concept for ensuring the nominee's long-term affiliation to the institution also after the ending of AvH Foundation sponsorship.

Award winners should carry out long-term, ground-breaking research at universities and research institutions in Germany. One objective of the programme is to tap academic expertise from abroad for research in Germany on a permanent basis; another is to support universities in redefining research focus areas. The position is for 5 years and the total award amount is Euro 3.5 to 5 million. It covers the financial outlay for research work and an administrative lump sum for the receiving institution. The award sum also includes personal salary which may not exceed €180,000 per year

### **E. For prospective leaders**

#### **13. German Chancellor Fellowship/ International Climate Protection Fellowship**

These fellowships are for candidates with leadership competence. The candidate must have Bachelor's or comparable degree completed less than 12 years ago. The application must be with own project proposal and approval of her/his host in Germany.

Every year, the AvH Foundation grants up to ten German Chancellor Fellowships to prospective leaders from the USA, the Russian Federation, China, India and Brazil respectively who have shown outstanding potential for leadership in their careers so far. The programme is targeted at accomplished young professionals who have influential voices in their respective fields. The fellowship enables fellows to come to Germany for 12 months in order to conduct a project with a host of their own choice.

The International Climate Protection Fellowships is for young climate experts and future leaders from transition and developing countries interested in conducting a project in Germany. It was announced for the first time in 2009. The program is financed by the Federal Ministry for the Environment, Nature Conservation and Nuclear Safety. Up to 20 fellowships is granted annually.

Fellows are free to choose their host in Germany to work on a research based project of their own choice in field of climatic protection.

## **Humboldt alumni**

From the very beginning, AvH Foundation has a saying “Once a Humboldtian – always a Humboldtian”. The Foundation is a lifetime partner, maintaining the connections to its alumni on a long-term basis through its alumni sponsorship programmes. The Foundation and its alumni have developed an active scientific network of more than 30,000 Humboldtians across the whole academic world – incorporating over 140 nations. The alumni sponsorship program provides support in the academic paths and development of Humboldtians. The Foundation encourages its alumni to undertake their own initiatives and collaborations across disciplinary and national borders.

The alumni sponsorship Programs of AvH includes: Further research stay of humboldtians – by this program alumni can renew their stay in Germany to refresh their knowledge and renew and extend their contact with German colleague after returning to their countries, by research group linkage program- linkage and collaborative works between huboldtians of common interest in their field of research, by Humboldt Colloquia and Kollegs- Humboldtians can run seminars, workshop inviting their colleagues AvH can finance such Kollegs, Humboldtians can form Humboldt Alumni Association in their country. First such association called Humboldt club was formed in 1966. Now there are such clubs in all most all nations and are collaborating with AvH foundation. Members of such club meet regularly, exchange idea and with financial support from AvH Foundation organise Humboldt Colloquia.

## **Humboldt Ambassador Scientist**

AvH Foundation tries to use the experiences of Humboldtians on German research and academic landscape in disseminating information about the AvH Foundation, its sponsoring programs and about Germany as research location in their country through Humboldt Ambassador Scientist. AvH Foundation appoints generally a Humboldtian as Humboldt Ambassador Scientist in a country. In 2006 the Humboldt Foundation’s Ambassador Scientists were appointed first time. An Ambassador supports the Foundation in an honorary capacity with information activities at home and abroad. The objective of AvH is to build up a worldwide network of Ambassador Scientists. The Foundation has assigned following roles to Humboldt Ambassador Scientist.

1. Assist in the dissemination of information about funding programs of AvH Foundation.
2. Building worldwide network of Ambassador Scientist. Find Humboldtians prepared to take on special role in spreading information in their own country about the programs of Foundation and about Germany as research location.
3. Humboldt Ambassador Scientists are asked to disseminate information on Germany as location for research and the programs of the AvH Foundation at their universities or research institutes. Ambassador also coordinates presentations by Humboldtians at other institutions in their own countries. Based on their local situation, they will be able to organize activities for disseminating information in any way they think suitable.

4. Humboldt Ambassador Scientists advise the AvH Foundation on promoting its programs in their countries. They also advise enquiries of other science organizations, ministries and institutions of higher education.

The Ambassador Scientist once a year report on their annual activities (works of past year). The AvH Foundation is particularly interested in observation on country's special feature, any difficulties, as well as Ambassador Scientists' suggestions for improvements. Such information helps in improvement in the offers for applicants of the Foundation, as well as to improve working conditions of Ambassador Scientists.

More information on fellowships of Alexander von Humboldt Foundation is found in the official website of AvH Foundation: [www.humboldt-foundation.de](http://www.humboldt-foundation.de)



Dr. Tribikram Bhattarai is a retired Professor of Tribhuvan University (TU), Kathmandu, Nepal. He got his MSc Degree in Botany from Tribhuvan University in 1979. Since 1980 he started teaching Botany and Biotechnology in B.Sc and M.Sc. levels of TU. DAAD fellowship was awarded to him from 1987 to 1992 for pursuing PhD Degree. University of Hohenheim, Stuttgart, Germany awarded him PhD degree in 1992. He also worked in University of Bayreuth, Germany in 2002/2003 for Postdoctoral research under the fellowship of Alexander von Humboldt Foundation, Germany. He has advance training in Biotechnology also from Israel and Taiwan. He worked as head of the Department during the establishment of Central Department of Biotechnology in TU and started MSc Biotechnology and PhD programs in the TU. After more than 38 years of service he retired from TU in 2018. He is life member of NEGAAS. Presently he is the Ambassador Scientist of Alexander von Humboldt Foundation. Email: [tribikrambhattarai@gmail.com](mailto:tribikrambhattarai@gmail.com)  
Tel: 9860187141

---

---

---

---

---

---

---

---

---

---

## Twists and Turns: Journey to Germany

"If you marry me, I will take you in this plane to Zurich, London, Rome and Paris". Raj Kapoor promised Vyjayanthimala in the Hindi movie "Sangam" and he kept his promise. The movie made such a deep impression upon me that I watched the movie six times. What had truly made me watch the movie multiple times was not that Raj Kapoor was able to keep his promise, but the beautiful sceneries of all those European cities in the movie. This was 1960s and in the absence of any modern visual media in those days, that was the very first instant that I had ever seen the images of western cities. I had only read about them in the books. The experience I had by watching that movie had completely changed my life. I got very much attached to the idea that I would one day travel to those cities and places and started dreaming. I did not have the faintest idea how such an opportunity would arise for a boy born and grown up in a then solitary paddy fields of Shankhamul with no educational environment at home or around. But the fate had already started to turn its wheels.

When I was around four years old, one of the richest and humble families of Patan came in contact with us. They were looking for a calm and quiet place close by where a few of its senior members could stay for a year or so. The paddy fields of then Shankhamul was near Patan and also isolated enough for the needed solitude. Our family heartily welcomed them and they stayed in our four storied house built in the middle of the paddy field for about a year. The guest family was so much satisfied with their stay that after an interval of about one year they again came to stay in our house for another year. During those two years quite a big number of their family members and relatives, all well-educated, came to visit almost every day. Some of their children would even come to our house and prepare their school home works. This created a good educational environment for us at home and gave a strong impetus to my father, who himself had no school education, to send his children to the school. So, on the advice of the senior family members of that family, my father admitted me and my elder sister to an only co-education school "Shree Chandi Vidya shram" in Patan. Coincidentally, the school had been established and run by that very family with their relatives. Their children went to this very same school. On the day of admission one of their elder sons, studying in the same school, gave me my new name – **Chandra Bahadur Joshi**.

In due course, I became very weak in mathematics, especially in geometry, so much so that I decided to avoid all the subjects where one had to deal with angles and triangles. Thus when I was given the option in the 9<sup>th</sup> class to choose subjects, I decided on "Aien Sresta (law and book keeping)" instead of compulsory mathematics, "Nagarik Shastra (Civics) instead of optional mathematics and History in place of Geography. I had no idea, where this choice would lead me to.

Fate had something else in store for me- nothing short of a miracle. One afternoon my maternal cousin came to visit us. It was a big surprise to me, since he did it very rarely. On that visit he had a few conversations with me. But, in one of those conversations he inquired about the optional subjects that I had chosen. He immediately got furious with my choice and asked me in a loud voice, "What do you want to become with all these nonsense subjects? Do you want to become a "Bahidar" (In those days Bahidar, meaning a clerk, is considered as the lowest position in the administrative hierarchy of the Government of Nepal)? After I explained my fear of geometry, he understood the mental blocks that I had been having. Within twenty minutes, he explained theorems one, three, four and five of school geometry (which are related with adjacent angles, vertical angles, similar triangles and isosceles triangles respectively). I don't know how, but everything clicked immediately and I clearly understood what geometry in fact was and how its theorems were proved and how problems were solved. Within a week after that fateful lesson, I became the master of all theorems and problems contained in that book. I will forever be indebted to my geometry teacher, **HARI Rudra Shrestha** of Nala, Kavre, the second son of my eldest maternal uncle who helped me overcome my fear of geometry and which ultimately enabled me to get admitted to Science College later leading to an engineering scholarship for further study in future. However, the story continues.

I could not secure enough marks in the intermediate examination (I. Sc.). As a result I could not get any scholarship to go abroad for further study. So I had no option but to continue with the bachelor class. I was disappointed sometime with myself and depressed to the extent that I was wasting all my time by doing something different than concentrating on my study. This went for more than a year until I realized that I was ruining my future. Then I started to devote my full time for the final examination and long before it started I knew almost everything in all the subjects that I had to know. Three months even before the examination had started, I was confident that I would score good marks and come out board first. But, unfortunately, I did not get even sixty percent marks. It was my nervousness during the entire examinations that ruined my examinations. I was nervous not because I could not answer the questions, but on the contrary, I knew the answers to all the questions and when presented with the opportunity to choose only a few to answer, I could not choose which one to answer and which one to leave. In all examination subjects, I would waste 15 to 20 minutes just to make a decision and then calm my mind and the body from being nervous. I would abruptly cancel the answer to a question that I had chosen to begin with, because I thought I should have better chosen another one. I would also give way too long answer to every question. My nervousness and lack of decision making ability and lack of skills in taking examinations because I knew too much took a toll in all the four papers in Physics and Chemistry. The bell would ring before I could hardly finish two-thirds or three-fourths of the question paper.

Highly frustrated I came back home and started studying throughout the night for the last examination on mathematics which had remained my only and last hope to get at least first division marks. i. e. 60 percent or more. Next day I went with a pale face and nervous mind to examination and waited for the question paper. As soon as I saw the paper I fell into complete darkness. I saw nothing around. The question paper also contained four questions derived from a single book. I had fully studied that book with more than two hundred questions and problems but had neglected to study altogether six questions because I had deemed them not significant and important. Out of the six questions, which I did not prepare were those very four questions asked in the examination. After around fifteen minutes I slowly opened my eyes and began to answer the questions. The first one I chose to answer was the one which I was sure that it would be asked in the examination and hence I had repeatedly practiced it several times at home. But even after forty five minutes I could not solve it. Then I picked up the next questions and so on. After about two hours I started having a severe headache and could not write any more. I left the hall to reach home as quickly as possible. I came down with a very high fever for a week. A few months later the results were out and despite my initial confidence that I would secure board first, I did not even secure the required sixty percent for the first division. One of my friends whom I had taught during the entire period of preparation for the exam secured exactly 60% and later he received the government scholarship for further study in a reputed university. He was the last to get those scholarships in that season. Despite the setbacks, I knew I had to keep on working hard.

So, I joined Master's program in Mathematics. I was not very interested in the subject but did not have a choice since there were no other available options at that time. However, shortly after a new Master's program in Physics and Chemistry was offered. I quickly switched and took up Chemistry and left mathematics behind. A few months later, a government notice was circulated in the daily newspaper offering scholarship to study cement technology in Germany. I was not very interested in the opportunity because it was only an undergraduate course and I did not have any idea about Germany and studies in Germany. So, I did not apply for it. But just a day before the due date of the application, one of my best friends insisted me that I should apply. Still not very convinced, I hesitatingly prepared all the required documents, went to Singha Durbar, the government office building, and waited in one of the office rooms of the Department of Education to make my final decision.

It was five minutes to five p.m., when I said to myself, "let's apply for it". So I headed towards the scholarship section and there I saw a man getting ready to head out. He was the last employee in that section about to leave for the day. I immediately recognized him as my old school friend, **HARI Das Shrestha** of Pimbahal, Patan. But, because of an unpleasant incident between us, we had not been speaking to each other for the last six years. I was about to turn back without saying anything to him, because I feared that he would just ignore me, or even deny to register my application by saying I was already late and would ask to come tomorrow. But turned out the fate had a different plan.

"I have to register an application", I told him without thinking even for a moment.

He took my application, opened the file cabinet, took out the file with applications and registered my application without speaking even a single word. I noted down the register number and came back home.

Within a couple of days I was called for the interview and I saw that I was the only one candidate. There were no other competitors and had there been others, I was pretty sure that I would be selected because all the others who had not yet received the scholarships earlier had much lower marks than me. So I was just waiting for the interview result to come and was making necessary preparation to go to Germany. Fate had plans but not without twists.

Not soon thereafter one day I heard a familiar male voice calling to me from outside my house "Chanbadur, hi Chanbadur!" I looked out of the window. My old friend Hari Das from the Education Ministry was standing with his bicycle. Extremely surprised I ran down the stairs to meet him. He was covered with sweat and was breathing as if he had just come from a bicycle race.

"What's the matter, Hari?" I asked him.

"What are you doing at home? Your name has been put in the alternative in selected candidate list. Someone else has been chosen for the scholarship. I have just finished typing his name. So do what you need to do. I have to run back to office." He turned his bicycle and rode from there very quickly. I became speechless and could not even thank him for the information.

Next day very early in the morning I rushed to one of my old friends in Makhan, Kathmandu. We had studied together for several months while preparing for B. Sc. exam. His name is **HARI Gopal Shrestha**. He took me to his neighbor, a gentleman of very high ranking position in the political arena and father to a son whom Hari Gopal had been tutoring. I explained the gentleman about the application and selection. Then he looked at his watch and within minutes he drove us in his jeep to the residence of the then education minister to explain the situation with my scholarship application.

On the following day I went to Singha Durbar to see the result. To my overwhelming joy, I saw my name on the top of the results. To my extreme surprise, there was also another name who had been selected for the scholarship, because application was asked for a single candidate only. Any way I was happy to see that someone is going together with me as a study partner to Germany and I was not going to be alone. This person became my study partner in Germany for about ten years and has

remained friend till today. He is also the one, with whom I traveled, two years after our arrival in Germany in 1966, to all those cities that I had dreamt of after watching the movie Sangam in 1964.

Fate had her own plans, but my journey to Germany would not have been possible without the fateful and extraordinary help from **THREE HARIS**. I would like to express my deepest gratitude to them, who were instrumental in helping me navigate those many twists and turns, prepare road for the journey to Germany and make my **DREAM COME TRUE**.

#### About Author



Prof. Dr. Chandra Bahadur Joshi is the founder President of NEGAAS established in 1987. He did his BSc from Tribhuvan University Nepal, Master in Mechanical Engineering from Technical University of Berlin in 1975 and PhD in Hydropower from the Indian Institute of Technology, Delhi in 1992. During the year 1999-2000, he was a Fulbright Postdoctoral Scholar in Colorado State University, USA. He has specialized in the field of New and Renewable Energy through training and research in the USA, Germany, Italy, UK, The Netherlands, Thailand, China and India

Email: [joshi.chandrab@gmail.com](mailto:joshi.chandrab@gmail.com)

## A glimpse into my life as an International Student in Berlin

**Sima Bhattarai**

Studying abroad had always been a desire of mine and Germany was my first choice. *Baba* had been a scholar in Germany and made several visits to the country for study/research purposes. We as a family were also fortunate to accompany him in one of his many stays there. That year in Germany has many of my favorite memories. So, it was only natural that I decided to study in Germany when the time came for me to decide on a country abroad for my masters. The facts, that I was already fluent in German language and that I would not need to pay tuition fees were the cherries on top.

After working as an architect for a couple of years in Nepal, I decided to get out of my comfort zone and study abroad. I wanted to pursue Urban Design for my masters. Exploring multiple options, I decided on attending the Technische Universität Berlin. So, in October, 2018 I left Kathmandu for Berlin, fairly excited to be spending the next 2-3 years of my life in Berlin, the capital city of Germany, by myself.

I came to the city knowing just a single person (a German family friend) living in Berlin, who had at that time already planned a 1.5-month trip to Nepal leaving just a 3-day window between the time I would arrive in Berlin and that she would be leaving for Nepal. She offered me her place to stay till she returned so I can look for an accommodation in peace. I only realized how fortunate I was later, for, finding an affordable room in Berlin was/is still a nightmare for many students in the recent years. The student hostels usually have a waiting time of 2-3 semesters. Needless to say, there was a slim chance of getting a proper place to stay from Nepal without having any connections. After two months of fruitless searching, thanks to this friend, I got a room in a WG (flat sharing) two houses away from her apartment almost immediately after she returned. This place was about 15km away from my university, which meant at least 45 mins of train ride to the university and back every day. This would be the normal commuting time for me, be it going to the university or meeting up with friends.

A week in the city and I was already impressed by the public transport network here. I could go from one point to another using the Bus and the train (U and S-Bahn) networks that are perfectly connected to one another. The best part was that as a student I did not have to worry about the ticket whatsoever, showing my student ID was enough to travel around freely within Berlin. It meant that I could travel around aimlessly and explore different parts of the city without ever worrying about the money I would spend on it. Going to different city parts and walking around soon became one of my favorite activities here, as the city of approx. 890 sq km offers a lot of culturally and historically rich sites that can be explored. Moreover, Berlin is one of the greenest cities in Europe and has a lot of green spaces in forms of parks, gardens, and forest areas, making walking in the city even more enjoyable.

At the university, I was the only student from Nepal in my faculty. There were students from all over the world, of different backgrounds, age and accomplishments which made the classroom itself an interesting learning platform. This was extremely different setup than what I was used to in Nepal. It gave me an opportunity to listen to different opinions, to discuss them and most importantly, to learn to respect other's opinions, even if I did not necessarily agree with them.

The course structure was also much flexible in comparison to Nepal. Apart from some compulsory modules, we were free to choose our own choice of subjects in each semester. Since I was used to rigid class routines, this needed some work to be adjusted to. It required self-discipline and planning; my study plans were my responsibility. There were no 'notes' given by the teachers that we would study for exams. The whole evaluation system in the university was also unique to the exam-oriented style in Nepal. I thoroughly enjoyed the fact that there was never an "exam" as such (In my faculty, at least) and almost all of the evaluations were based on class presentations, assignments and research work done throughout the semester. In the classroom we were always encouraged to have and speak our own opinion. What I really appreciated was the fact that we were even asked for our critics for every subject and faculty at the end of each semester.

My first days at the university, I struggled with the feeling of not being at par with my fellow classmates. It wasn't because of anything they did or said but because of the numerous times I have heard how advanced the cities in the West are or how backward we are in our education and so on and so forth. It took me a few months and a number of heart to heart with my fellow class mates to realize and understand that everyone was going through the same struggle understanding the texts and books we were supposed to be learning and that everyone was learning,..... just like me. Actually, being fluent in German, I had an advantage in comparison to non-German speakers. Although our master's course was an "international degree" that could be completed in English, knowing the German language was required for a lot of the interaction we would make in and for our classes.

One of the important things I think I gained from my time in Germany is to understand Nepal better. This sounds contradictory but staying abroad made me realize how little I knew about my country, our history, and our culture. For example, I felt like I knew more about the history of European architecture than the history of Nepalese architecture. This realization motivated me to be constantly reading and learning more about Nepal in different contexts. Having said that, the stay has also taught me to appreciate and understand the differences in the world and to respect others perspective. Staying abroad has also made me realize that no country is perfect and that each has its own share of problems. Especially how we tend to underestimate the value of what we have near/around us.

Everyday has been a living experience. I have learnt to be open minded but also to question and critically think of everything I see or learn. It has been a wonderful opportunity for refreshing my language skills, making new friends, and learning a new culture. However, it has not been all sunshine and there have been days I have struggled adopting to new environment and missing home. As the whole world is being terrorized by the corona virus, Germany has been no exception. My life in the last year here has changed completely- adapting to digital learning, not being able to physically meet my fellow classmates or travel as much as I would like to. Social interaction with my friends and colleagues has almost come to a halt but well writing about this would make an entirely different story. However, I think studying abroad is a phenomenal experience, as well as a great journey of discovering oneself and would definitely recommend it to anyone thinking about it.



Sima Bhattarai has completed her Bachelor degree in Architect from Tribhuvan University and presently she is studding Master in Urban Design last Semester in Technische Universitaet Berlin, Germany.

Email: [bhattaraicma@gmail.com](mailto:bhattaraicma@gmail.com)